

SPADE DRILLS and Holders

www.europatool.co.uk

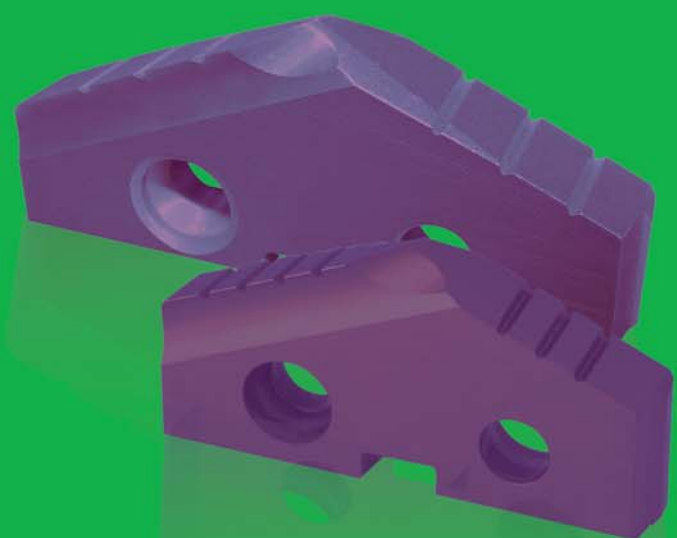



Europa Tool 8TH EDITION

NEW PRODUCT-SPADE DRILL

PRODUCTS	SERIES	COATING	DESCRIPTION	PAGE
	807304 807306 807326	TiN TiCN TiAlN	SERIES 1, 2 SPADE THROW-AWAY DRILL INSERTS(M-4)	227
	807304 807306 807326	TiN TiCN TiAlN	SERIES 3 SPADE THROW-AWAY DRILL INSERTS(M-4)	228
	807304 807306 807326	TiN TiCN TiAlN	SERIES 4 SPADE THROW-AWAY DRILL INSERTS(M-4)	229
	807394 807396 807386	TiN TiCN TiAlN	SERIES 5, 6 SPADE THROW-AWAY DRILL INSERTS(M-4)	230
	807394 807396 807386	TiN TiCN TiAlN	SERIES 7, 8 SPADE THROW-AWAY DRILL INSERTS(M-4)	231
	808317 808318 808327	TiN TiCN TiAlN	SERIES Y, Z, O SPADE THROW-AWAY DRILL INSERTS(T-15)	232
	808317 808318 808327	TiN TiCN TiAlN	SERIES 1, 2 SPADE THROW-AWAY DRILL INSERTS(T-15)	233
	808317 808318 808327	TiN TiCN TiAlN	SERIES 3 SPADE THROW-AWAY DRILL INSERTS(T-15)	234
	808317 808318 808327	TiN TiCN TiAlN	SERIES 4 SPADE THROW-AWAY DRILL INSERTS(T-15)	235
	809305 809307 809321	TiN TiCN TiAlN	SERIES Y, Z, O SPADE THROW-AWAY DRILL INSERTS(M-48)	236
	809305 809307 809321	TiN TiCN TiAlN	SERIES 1, 2 SPADE THROW-AWAY DRILL INSERTS(M-48)	237
	832308 832309 832323	TiN TiCN TiAlN	SERIES Y, Z, O SPADE THROW-AWAY DRILL INSERTS(K-10)	238
	832308 832309 832323	TiN TiCN TiAlN	SERIES 1, 2 SPADE THROW-AWAY DRILL INSERTS(K-10)	239
	830308 830309 830323	TiN TiCN TiAlN	SERIES Y, Z, O SPADE THROW-AWAY DRILL INSERTS(K-20)	240
	830308 830309 830323	TiN TiCN TiAlN	SERIES 1, 2 SPADE THROW-AWAY DRILL INSERTS(K-20)	241
	830308 830309 830323	TiN TiCN TiAlN	SERIES 3 SPADE THROW-AWAY DRILL INSERTS(K-20)	242

NEW PRODUCT-SPADE DRILL

NEW PRODUCT-HOLDER

PRODUCTS	SERIES	COATING	DESCRIPTION	PAGE
	831308 831309 831323	TiN TiCN TiAlN	SERIES Y, Z, O SPADE THROW-AWAY DRILL INSERTS(P-40)	243
	831308 831309 831323	TiN TiCN TiAlN	SERIES 1, 2 SPADE THROW-AWAY DRILL INSERTS(P-40)	244
	831308 831309 831323	TiN TiCN TiAlN	SERIES 3 SPADE THROW-AWAY DRILL INSERTS(P-40)	245
CUTTING DATA				246 ~ 247

PRODUCTS	SERIES	DESCRIPTION	PAGE
	892150	TAPER SHANK HOLDER SHORT LENGTH-Straight Flute	250
	853250	TAPER SHANK HOLDER INTERMEDIATE LENGTH-Spiral Flute	250
	894250	TAPER SHANK HOLDER STANDARD LENGTH- Spiral Flute	251
	855250	TAPER SHANK HOLDER EXTENDED LENGTH- Spiral Flute	252
	895150	TAPER SHANK HOLDER EXTENDED LENGTH- Straight Flute	252
	842250	FLANGED STRAIGHT SHANK HOLDER STUB LENGTH-Straight Flute	253
	872150	FLANGED STRAIGHT SHANK HOLDER SHORT LENGTH-Straight Flute	253
	863250	FLANGED STRAIGHT SHANK HOLDER INTERMEDIATE LENGTH-Spiral Flute	254
	874250	FLANGED STRAIGHT SHANK HOLDER STANDARD LENGTH-Spiral Flute	254
	855250	FLANGED STRAIGHT SHANK HOLDER EXTENDED LENGTH-Spiral Flute	255
	875150	FLANGED STRAIGHT SHANK HOLDER EXTENDED LENGTH-Straight Flute	255
		HOLDER ACCESSORIES ROTARY COOLANT ADAPTER(RCA) AND ACCESSORIES	256
		TORX SCREWS	256

SPADE Throw-Away Drill Inserts-HSS M4

- For general use in steels and cast irons.
- Reduce set-up time, it easily can be replaced on the machine.
- Any non-standard size available.40



SERIES 1, 2

Series Min. to Max. (mm/inch)	Diameter			Thick Metric (mm/inch)	EDP No.		
	Inch (inch)	Metric (mm)	Decimal (inch)		TiN	TiCN	TiAlN
1 17.53 (.690") to 24.38 (.960")	45/64"	17.86	.7031"	4.0 (5/32")	8073041786	8073061786	8073261786
		18.00	.7087"		8073041800	8073061800	8073261800
	23/32"	18.26	.7188"		8073041826	8073061826	8073261826
		18.50	.7283"		8073041850	8073061850	8073261850
	47/64"	18.65	.7344"		8073041865	8073061865	8073261865
		19.00	.7480"		8073041900	8073061900	8073261900
	3/4"	19.05	.7500"		8073041905	8073061905	8073261905
	49/64"	19.45	.7656"		8073041945	8073061945	8073261945
		19.50	.7677"		8073041950	8073061950	8073261950
	25/32"	19.84	.7812"		8073041984	8073061984	8073261984
		20.00	.7874"		8073042000	8073062000	8073262000
	51/64"	20.24	.7969"		8073042024	8073062024	8073262024
		20.50	.8071"		8073042050	8073062050	8073262050
	13/16"	20.64	.8125"		8073042064	8073062064	8073262064
		21.00	.8268"		8073042100	8073062100	8073262100
	27/32"	21.43	.8438"		8073042143	8073062143	8073262143
	55/64"	21.83	.8594"		8073042183	8073062183	8073262183
		22.00	.8661"		8073042200	8073062200	8073262200
	7/8"	22.23	.8750"		8073042223	8073062223	8073262223
	57/64"	22.62	.8906"		8073042262	8073062262	8073262262
		23.00	.9055"		8073042300	8073062300	8073262300
	29/32"	23.02	.9062"		8073042302	8073062302	8073262302
	59/64"	23.42	.9219"		8073042342	8073062342	8073262342
	15/16"	23.81	.9375"		8073042381	8073062381	8073262381
		24.00	.9449"		8073042400	8073062400	8073262400
	2 24.41 (.961") to 35.05 (1.380")	31/32"	24.61		.9688"	4.8 (3/16")	8073042461
63/64"		25.00	.9843"	8073042500	8073062500		8073262500
1"		25.40	1.0000"	8073042540	8073062540		8073262540
1-1/64"		25.80	1.0156"	8073042580	8073062580		8073262580
		26.00	1.0236"	8073042600	8073062600		8073262600
1-1/32"		26.19	1.0312"	8073042619	8073062619		8073262619
1-3/64"		26.59	1.0469"	8073042659	8073062659		8073262659
1-1/16"		26.99	1.0625"	8073042699	8073062699		8073262699
		27.00	1.0630"	8073042700	8073062700		8073262700
1-3/32"		27.78	1.0938"	8073042778	8073062778		8073262778
		28.00	1.1024"	8073042800	8073062800		8073262800
1-7/64"		28.18	1.1094"	8073042818	8073062818		8073262818
1-1/8"		28.58	1.1250"	8073042858	8073062858		8073262858
		29.00	1.1417"	8073042900	8073062900		8073262900
1-5/32"		29.37	1.1562"	8073042937	8073062937		8073262937
		30.00	1.1811"	8073043000	8073063000		8073263000
1-3/16"		30.16	1.1875"	8073043016	8073063016		8073263016
1-7/32"		30.96	1.2188"	8073043096	8073063096		8073263096
		31.00	1.2205"	8073043100	8073063100		8073263100
1-1/4"		31.75	1.2500"	8073043175	8073063175		8073263175
		32.00	1.2598"	8073043200	8073063200		8073263200
1-9/32"		32.54	1.2812"	8073043254	8073063254		8073263254
		33.00	1.2992"	8073043300	8073063300		8073263300
1-5/16"		33.34	1.3125"	8073043334	8073063334		8073263334
		34.00	1.3386"	8073043400	8073063400		8073263400
1-11/32"		34.13	1.3438"	8073043413	8073063413		8073263413
1-3/8"	34.93	1.3750"	8073043493	8073063493	8073263493		
	35.00	1.3780"	8073043500	8073063500	8073263500		

SPADE Throw-Away Drill Inserts-HSS M4

- For general use in steels and cast irons.
- Reduce set-up time, it easily can be replaced on the machine.
- Any non-standard size available.40



SERIES 3

Series Min. to Max. (mm/inch)	Diameter			Thick Metric (mm/inch)	EDP No.		
	Inch (inch)	Metric (mm)	Decimal (inch)		TiN	TiCN	TiAlN
3 34.37 (1.353") to 47.80 (1.882")	1-13/32"	35.72	1.4062"	6.4 (1/4")	8073043572	8073063572	8073263572
		36.00	1.4173"		8073043600	8073063600	8073263600
	1-7/16"	36.51	1.4375"		8073043651	8073063651	8073263651
		37.00	1.4567"		8073043700	8073063700	8073263700
	1-15/32"	37.31	1.4688"		8073043731	8073063731	8073263731
		38.00	1.4961"		8073043800	8073063800	8073263800
	1-1/2"	38.10	1.5000"		8073043810	8073063810	8073263810
	1-17/32"	38.89	1.5312"		8073043889	8073063889	8073263889
		39.00	1.5354"		8073043900	8073063900	8073263900
	1-9/16"	39.69	1.5625"		8073043969	8073063969	8073263969
		40.00	1.5748"		8073044000	8073064000	8073264000
	1-19/32"	40.48	1.5938"		8073044048	8073064048	8073264048
		41.00	1.6142"		8073044100	8073064100	8073264100
	1-5/8"	41.28	1.6250"		8073044128	8073064128	8073264128
		42.00	1.6535"		8073044200	8073064200	8073264200
	1-21/32"	42.07	1.6562"		8073044207	8073064207	8073264207
	1-11/16"	42.86	1.6875"		8073044286	8073064286	8073264286
		43.00	1.6929"		8073044300	8073064300	8073264300
	1-23/32"	43.66	1.7188"		8073044366	8073064366	8073264366
		44.00	1.7323"		8073044400	8073064400	8073264400
	1-3/4"	44.45	1.7500"		8073044445	8073064445	8073264445
		45.00	1.7717"		8073044500	8073064500	8073264500
	1-25/32"	45.24	1.7812"		8073044524	8073064524	8073264524
		46.00	1.8110"		8073044600	8073064600	8073264600
	1-13/16"	46.04	1.8125"		8073044604	8073064604	8073264604
	1-27/32"	46.83	1.8438"		8073044683	8073064683	8073264683
	47.00	1.8504"	8073044700	8073064700	8073264700		
1-7/8"	47.63	1.8750"	8073044763	8073064763	8073264763		



SPADE Throw-Away Drill Inserts-HSS M4

- For general use in steels and cast irons.
- Reduce set-up time, it easily can be replaced on the machine.
- Any non-standard size available.



SERIES 4

Series Min. to Max. (mm/inch)	Diameter			Thick Metric (mm/inch)	EDP No.		
	Inch (inch)	Metric (mm)	Decimal (inch)		TiN	TiCN	TiAlN
4 46.99 (1.850") to 65.28 (2.570")	1-29/32"	48.00	1.8898"	7.9 (5/16")	8073044800	8073064800	8073264800
		48.42	1.9062"		8073044842	8073064842	8073264842
		49.00	1.9291"		8073044900	8073064900	8073264900
	1-15/16"	49.21	1.9375"		8073044921	8073064921	8073264921
		50.00	1.9685"		8073045000	8073065000	8073265000
	1-31/32"	50.01	1.9688"		8073045001	8073065001	8073265001
	2"	50.80	2.0000"		8073045080	8073065080	8073265080
		51.00	2.0079"		8073045100	8073065100	8073265100
	2-1/32"	51.59	2.0312"		8073045159	8073065159	8073265159
	2-3/64"	52.00	2.0472"		8073045200	8073065200	8073265200
	2-1/16"	52.39	2.0625"		8073045239	8073065239	8073265239
		53.00	2.0866"		8073045300	8073065300	8073265300
	2-3/32"	53.18	2.0938"		8073045318	8073065318	8073265318
	2-1/8"	53.98	2.1250"		8073045398	8073065398	8073265398
		54.00	2.1260"		8073045400	8073065400	8073265400
	2-5/32"	54.79	2.1562"		8073045479	8073065479	8073265479
		55.00	2.1654"		8073045500	8073065500	8073265500
	2-3/16"	55.56	2.1875"		8073045556	8073065556	8073265556
		56.00	2.2047"		8073045600	8073065600	8073265600
	2-7/32"	56.36	2.2188"		8073045636	8073065636	8073265636
		57.00	2.2441"		8073045700	8073065700	8073265700
	2-1/4"	57.15	2.2500"		8073045715	8073065715	8073265715
	2-9/32"	57.94	2.2812"		8073045794	8073065794	8073265794
		58.00	2.2835"		8073045800	8073065800	8073265800
	2-5/16"	58.74	2.3125"		8073045874	8073065874	8073265874
		59.00	2.3228"		8073045900	8073065900	8073265900
	2-11/32"	59.53	2.3438"		8073045953	8073065953	8073265953
		60.00	2.3622"		8073046000	8073066000	8073266000
	2-3/8"	60.33	2.3750"		8073046033	8073066033	8073266033
		61.00	2.4016"		8073046100	8073066100	8073266100
	2-13/32"	61.12	2.4062"		8073046112	8073066112	8073266112
	2-7/16"	61.91	2.4375"		8073046191	8073066191	8073266191
	62.00	2.4409"	8073046200	8073066200	8073266200		
2-15/32"	62.71	2.4688"	8073046271	8073066271	8073266271		
	63.00	2.4803"	8073046300	8073066300	8073266300		
2-1/2"	63.50	2.5000"	8073046350	8073066350	8073266350		
	64.00	2.5197"	8073046400	8073066400	8073266400		
2-17/32"	64.29	2.5312"	8073046429	8073066429	8073266429		
	65.00	2.5591"	8073046500	8073066500	8073266500		
2-9/16"	65.09	2.5625"	8073046509	8073066509	8073266509		

SPADE Throw-Away Drill Inserts-HSS M4

- For general use in steels and cast irons.
- Reduce set-up time, it easily can be replaced on the machine.
- Any non-standard size available.



SERIES 5, 6

Series Min. to Max. (mm/inch)	Diameter			Thick Metric (mm/inch)	EDP No.		
	Inch (inch)	Metric (mm)	Decimal (inch)		TiN	TiCN	TiAlN
5 62.38 (2.456") to 76.20 (3.000")	2-1/2"	63.50	2.5000"	11.1 (7/16")	8073946350	8073966350	8073866350
		64.00	2.5197"		8073946400	8073966400	8073866400
	2-17/32"	64.29	2.5312"		8073946429	8073966429	8073866429
	2-9/16"	65.09	2.5625"		8073946509	8073966509	8073866509
	2-19/32"	65.88	2.5938"		8073046588	8073066588	8073266588
		66.00	2.5984"		8073046600	8073066600	8073266600
	2-5/8"	66.68	2.6250"		8073046668	8073066668	8073266668
	2-21/32"	67.47	2.6562"		8073046747	8073066747	8073266747
		68.00	2.6772"		8073046800	8073066800	8073266800
	2-11/16"	68.26	2.6875"		8073046826	8073066826	8073266826
	2-23/32"	69.05	2.7188"		8073046905	8073066905	8073266905
	2-3/4"	69.85	2.7500"		8073046985	8073066985	8073266985
		70.00	2.7559"		8073047000	8073067000	8073267000
	2-25/32"	70.64	2.7812"		8073047064	8073067064	8073267064
	2-13/16"	71.44	2.8125"		8073047144	8073067144	8073267144
		72.00	2.8346"		8073047200	8073067200	8073267200
	2-27/32"	72.23	2.8438"		8073047223	8073067223	8073267223
	2-7/8"	73.03	2.8750"		8073047303	8073067303	8073267303
	2-29/32"	73.82	2.9062"		8073047382	8073067382	8073267382
		74.00	2.9134"		8073047400	8073067400	8073267400
	2-15/16"	74.61	2.9375"		8073047461	8073067461	8073267461
	2-31/32"	75.41	2.9688"		8073047541	8073067541	8073267541
	76.00	2.9921"	8073047600	8073067600	8073267600		
3"	76.20	3.0000"	8073047620	8073067620	8073267620		
6 76.23 (3.001") to 89.08 (3.507")	3-1/32"	76.99	3.0312"	11.1 (7/16")	8073047699	8073067699	8073267699
	3-1/16"	77.79	3.0625"		8073047779	8073067779	8073267779
		78.00	3.0709"		8073047800	8073067800	8073267800
	3-3/32"	78.58	3.0938"		8073047858	8073067858	8073267858
	3-1/8"	79.38	3.1250"		8073047938	8073067938	8073267938
		80.00	3.1496"		8073048000	8073068000	8073268000
	3-5/32"	80.17	3.1562"		8073048017	8073068017	8073268017
	3-3/16"	80.96	3.1875"		8073048096	8073068096	8073268096
	3-7/32"	81.76	3.2188"		8073048176	8073068176	8073268176
		82.00	3.2283"		8073048200	8073068200	8073268200
	3-1/4"	82.55	3.2500"		8073048255	8073068255	8073268255
	3-9/32"	83.34	3.2812"		8073048334	8073068334	8073268334
		84.00	3.3071"		8073048400	8073068400	8073268400
	3-5/16"	84.14	3.3125"		8073048414	8073068414	8073268414
	3-11/32"	84.93	3.3438"		8073048493	8073068493	8073268493
	3-3/8"	85.73	3.3750"		8073048573	8073068573	8073268573
		86.00	3.3858"		8073048600	8073068600	8073268600
	3-13/32"	86.52	3.4062"		8073048652	8073068652	8073268652
3-7/16"	87.31	3.4375"	8073048731	8073068731	8073268731		
	88.00	3.4646"	8073048800	8073068800	8073268800		
3-15/32"	88.11	3.4688"	8073048811	8073068811	8073268811		
3-1/2"	88.90	3.5000"	8073048890	8073068890	8073268890		

SPADE Throw-Away Drill Inserts-HSS M4

- For general use in steels and cast irons.
- Reduce set-up time, it easily can be replaced on the machine.
- Any non-standard size available.



SERIES 7, 8

Series Min. to Max. (mm/inch)	Diameter			Thick Metric (mm/inch)	EDP No.		
	Inch (inch)	Metric (mm)	Decimal (inch)		TiN	TiCN	TiAlN
7 87.76 (3.455") to 101.60 (4.000")	3-17/32"	89.69	3.5312"	11.1 (7/16")	8073048969	8073068969	8073268969
		90.00	3.5433"		8073049000	8073069000	8073269000
	3-9/16"	90.49	3.5625"		8073049049	8073069049	8073269049
		3-19/32"	91.28		3.5938"	8073049128	8073069128
	92.00		3.6221"		8073049200	8073069200	8073269200
	3-5/8"	92.08	3.6250"		8073049208	8073069208	8073269208
		3-21/32"	92.87		3.6562"	8073049287	8073069287
	3-11/16"		93.66		3.6875"	8073049366	8073069366
		94.00	3.7008"		8073049400	8073069400	8073269400
	3-23/32"	94.46	3.7188"		8073049446	8073069446	8073269446
		3-3/4"	95.25		3.7500"	8073049525	8073069525
	96.00		3.7795"		8073049600	8073069600	8073269600
	3-25/32"	96.04	3.7812"		8073049604	8073069604	8073269604
		3-13/16"	96.84		3.8125"	8073049684	8073069684
	3-27/32"		97.63		3.8438"	8073049763	8073069763
		98.00	3.8583"		8073049800	8073069800	8073269800
	3-7/8"	98.43	3.8750"		8073049843	8073069843	8073269843
		3-29/32"	99.22		3.9062"	8073049922	8073069922
	100.00		3.9370"		80730410000	80730610000	80732610000
	3-15/16"	100.01	3.9375"		80730410001	80730610001	80732610001
3-31/32"		100.81	3.9688"	80730410081	80730610081	80732610081	
	4"	101.60	4.0000"	80730410160	80730610160	80732610160	
8 101.63 (4.001") to 114.48 (4.507")		4-1/64"	102.00	4.0156"	80730410200	80730610200	80732610200
	4-1/16"	103.19	4.0625"	80730410319	80730610319	80732610319	
	4-3/32"	104.00	4.0945"	80730410400	80730610400	80732610400	
		104.78	4.1250"	80730410478	80730610478	80732610478	
	4-1/8"	106.00	4.1732"	80730410600	80730610600	80732610600	
		106.36	4.1875"	80730410636	80730610636	80732610636	
	4-1/4"	107.95	4.2500"	80730410795	80730610795	80732610795	
		108.00	4.2520"	80730410800	80730610800	80732610800	
	4-5/16"	109.54	4.3125"	80730410954	80730610954	80732610954	
		110.00	4.3307"	80730411000	80730611000	80732611000	
	4-3/8"	111.13	4.3750"	80730411113	80730611113	80732611113	
		112.00	4.4094"	80730411200	80730611200	80732611200	
	4-7/16"	112.71	4.4375"	80730411271	80730611271	80732611271	
		114.00	4.4882"	80730411400	80730611400	80732611400	
	4-1/2"	114.30	4.5000"	80730411430	80730611430	80732611430	

SPADE Throw-Away Drill Inserts-HSS T15

- For use in high nickel alloys and materials over 280 Brinell.
- Reduce set-up time, it easily can be replaced on the machine.
- Any non-standard size available.



SERIES Y, Z, O

Series Min. to Max. (mm/inch)	Diameter			Thick Metric (mm/inch)	EDP No.		
	Inch (inch)	Metric (mm)	Decimal (inch)		TiN	TiCN	TiAlN
Y 9.50(.374") to 11.07(.436")	3/8"	9.50	.3740"	2.4 (3/32")	8083170950	8083180950	8083270950
		9.53	.3750"		8083170953	8083180953	8083270953
	25/64"	9.80	.3860"		8083170980	8083180980	8083270980
		9.92	.3906"		8083170992	8083180992	8083270992
		10.00	.3937"		8083171000	8083181000	8083271000
		10.20	.4016"		8083171020	8083181020	8083271020
	13/32"	10.32	.4063"		8083171032	8083181032	8083271032
		10.50	.4134"		8083171050	8083181050	8083271050
	27/64"	10.72	.4219"		8083171072	8083181072	8083271072
		10.80	.4252"		8083171080	8083181080	8083271080
11.00	.4331"	8083171100	8083181100	8083271100			
Z 11.11(.437") to 12.95(.510")	7/16"	11.11	.4375"	2.4 (3/32")	8083171111	8083181111	8083271111
	29/64"	11.50	.4528"		8083171150	8083181150	8083271150
		11.51	.4531"		8083171151	8083181151	8083271151
	15/32"	11.91	.4688"		8083171191	8083181191	8083271191
		12.00	.4724"		8083171200	8083181200	8083271200
	31/64"	12.30	.4844"		8083171230	8083181230	8083271230
1/2"	12.50	.4921"	8083171250	8083181250	8083271250		
12.70	.5000"	8083171270	8083181270	8083271270			
O 12.98 (.511") to 17.65 (.695")	33/64"	13.00	.5118"	3.2 (1/8")	8083171300	8083181300	8083271300
		13.10	.5156"		8083171310	8083181310	8083271310
	17/32"	13.49	.5313"		8083171349	8083181349	8083271349
		13.50	.5315"		8083171350	8083181350	8083271350
	35/64"	13.89	.5469"		8083171389	8083181389	8083271389
		14.00	.5512"		8083171400	8083181400	8083271400
	9/16"	14.29	.5625"		8083171429	8083181429	8083271429
		14.50	.5709"		8083171450	8083181450	8083271450
	37/64"	14.68	.5781"		8083171468	8083181468	8083271468
		15.00	.5906"		8083171500	8083181500	8083271500
	19/32"	15.08	.5938"		8083171508	8083181508	8083271508
		15.48	.6094"		8083171548	8083181548	8083271548
	39/64"	15.50	.6102"		8083171550	8083181550	8083271550
		15.88	.6250"		8083171588	8083181588	8083271588
	5/8"	16.00	.6299"		8083171600	8083181600	8083271600
		16.27	.6406"		8083171627	8083181627	8083271627
	41/64"	16.50	.6496"		8083171650	8083181650	8083271650
		16.67	.6563"		8083171667	8083181667	8083271667
	21/32"	17.00	.6693"		8083171700	8083181700	8083271700
		17.07	.6719"		8083171707	8083181707	8083271707
43/64"	17.46	.6875"	8083171746	8083181746	8083271746		
	17.50	.6890"	8083171750	8083181750	8083271750		

SPADE Throw-Away Drill Inserts-HSS T15

- For use in high nickel alloys and materials over 280 Brinell.
- Reduce set-up time, it easily can be replaced on the machine.
- Any non-standard size available.



SERIES 1, 2

Series Min. to Max. (mm/inch)	Diameter			Thick Metric (mm/inch)	EDP No.			
	Inch (inch)	Metric (mm)	Decimal (inch)		TiN	TiCN	TiAlN	
1 17.53 (.690") to 24.38 (.960")	45/64"	17.86	.7031"	4.0 (5/32")	8083171786	8083181786	8083271786	
		18.00	.7087"		8083171800	8083181800	8083271800	
	23/32"	18.26	.7188"		8083171826	8083181826	8083271826	
		18.50	.7283"		8083171850	8083181850	8083271850	
	47/64"	18.65	.7344"		8083171865	8083181865	8083271865	
		19.00	.7480"		8083171900	8083181900	8083271900	
	3/4"	19.05	.7500"		8083171905	8083181905	8083271905	
	49/64"	19.45	.7656"		8083171945	8083181945	8083271945	
		19.50	.7677"		8083171950	8083181950	8083271950	
	25/32"	19.84	.7813"		8083171984	8083181984	8083271984	
		20.00	.7874"		8083172000	8083182000	8083272000	
	51/64"	20.24	.7969"		8083172024	8083182024	8083272024	
		20.50	.8071"		8083172050	8083182050	8083272050	
	13/16"	20.64	.8125"		8083172064	8083182064	8083272064	
		21.00	.8268"		8083172100	8083182100	8083272100	
	27/32"	21.43	.8438"		8083172143	8083182143	8083272143	
	55/64"	21.83	.8594"		8083172183	8083182183	8083272183	
		22.00	.8661"		8083172200	8083182200	8083272200	
	7/8"	22.23	.8750"		8083172223	8083182223	8083272223	
	57/64"	22.62	.8906"		8083172262	8083182262	8083272262	
		23.00	.9055"		8083172300	8083182300	8083272300	
	29/32"	23.02	.9063"		8083172302	8083182302	8083272302	
	59/64"	23.42	.9219"		8083172342	8083182342	8083272342	
	15/16"	23.81	.9375"		8083172381	8083182381	8083272381	
		24.00	.9449"		8083172400	8083182400	8083272400	
	2 24.41 (.961") to 35.05 (1.380")	31/32"	24.61		.9688"	8083172461	8083182461	8083272461
		63/64"	25.00		.9843"	8083172500	8083182500	8083272500
		1"	25.40		1.0000"	8083172540	8083182540	8083272540
1-1/64"		25.80	1.0156"	8083172580	8083182580	8083272580		
		26.00	1.0236"	8083172600	8083182600	8083272600		
1-1/32"		26.19	1.0313"	8083172619	8083182619	8083272619		
1-3/64"		26.59	1.0469"	8083172659	8083182659	8083272659		
1-1/16"		26.99	1.0625"	8083172699	8083182699	8083272699		
		27.00	1.0630"	8083172700	8083182700	8083272700		
1-3/32"		27.78	1.0938"	8083172778	8083182778	8083272778		
		28.00	1.1024"	8083172800	8083182800	8083272800		
1-7/64"		28.18	1.1094"	8083172818	8083182818	8083272818		
1-1/8"		28.58	1.1250"	8083172858	8083182858	8083272858		
		29.00	1.1417"	8083172900	8083182900	8083272900		
1-5/32"		29.37	1.1563"	8083172937	8083182937	8083272937		
		30.00	1.1811"	8083173000	8083183000	8083273000		
1-3/16"		30.16	1.1875"	8083173016	8083183016	8083273016		
1-7/32"		30.96	1.2188"	8083173096	8083183096	8083273096		
		31.00	1.2205"	8083173100	8083183100	8083273100		
1-1/4"		31.75	1.2500"	8083173175	8083183175	8083273175		
		32.00	1.2598"	8083173200	8083183200	8083273200		
1-9/32"		32.54	1.2813"	8083173254	8083183254	8083273254		
		33.00	1.2992"	8083173300	8083183300	8083273300		
1-5/16"		33.34	1.3125"	8083173334	8083183334	8083273334		
		34.00	1.3386"	8083173400	8083183400	8083273400		
1-11/32"		34.13	1.3438"	8083173413	8083183413	8083273413		
1-3/8"		34.93	1.3750"	8083173493	8083183493	8083273493		
		35.00	1.3780"	8083173500	8083183500	8083273500		

SPADE Throw-Away Drill Inserts-HSS T15

- For use in high nickel alloys and materials over 280 Brinell.
- Reduce set-up time, it easily can be replaced on the machine.
- Any non-standard size available.



SERIES 3

Series Min. to Max. (mm/inch)	Diameter			Thick Metric (mm/inch)	EDP No.		
	Inch (inch)	Metric (mm)	Decimal (inch)		TiN	TiCN	TiAlN
3 34.37 (1.353") to 47.80 (1.882")	1-13/32"	35.72	1.4063"	6.4 (1/4")	8083173572	8083183572	8083273572
		36.00	1.4173"		8083173600	8083183600	8083273600
	1-7/16"	36.51	1.4375"		8083173651	8083183651	8083273651
		37.00	1.4567"		8083173700	8083183700	8083273700
	1-15/32"	37.31	1.4688"		8083173731	8083183731	8083273731
		38.00	1.4961"		8083173800	8083183800	8083273800
	1-1/2"	38.10	1.5000"		8083173810	8083183810	8083273810
	1-17/32"	38.89	1.5313"		8083173889	8083183889	8083273889
		39.00	1.5354"		8083173900	8083183900	8083273900
	1-9/16"	39.69	1.5625"		8083173969	8083183969	8083273969
		40.00	1.5748"		8083174000	8083184000	8083274000
	1-19/32"	40.48	1.5938"		8083174048	8083184048	8083274048
		41.00	1.6142"		8083174100	8083184100	8083274100
	1-5/8"	41.28	1.6250"		8083174128	8083184128	8083274128
		42.00	1.6535"		8083174200	8083184200	8083274200
	1-21/32"	42.07	1.6563"		8083174207	8083184207	8083274207
	1-11/16"	42.86	1.6875"		8083174286	8083184286	8083274286
		43.00	1.6929"		8083174300	8083184300	8083274300
	1-23/32"	43.66	1.7188"		8083174366	8083184366	8083274366
		44.00	1.7323"		8083174400	8083184400	8083274400
	1-3/4"	44.45	1.7500"		8083174445	8083184445	8083274445
		45.00	1.7717"		8083174500	8083184500	8083274500
	1-25/32"	45.24	1.7813"		8083174524	8083184524	8083274524
		46.00	1.8110"		8083174600	8083184600	8083274600
	1-13/16"	46.04	1.8125"		8083174604	8083184604	8083274604
	1-27/32"	46.83	1.8438"		8083174683	8083184683	8083274683
		47.00	1.8504"		8083174700	8083184700	8083274700
	1-7/8"	47.63	1.8750"		8083174763	8083184763	8083274763

SPADE Throw-Away Drill Inserts-HSS T15

- For use in high nickel alloys and materials over 280 Brinell.
- Reduce set-up time, it easily can be replaced on the machine.
- Any non-standard size available.



SERIES 4

Series Min. to Max. (mm/inch)	Diameter			Thick Metric (mm/inch)	EDP No.		
	Inch (inch)	Metric (mm)	Decimal (inch)		TiN	TiCN	TiAlN
4 46.99 (1.850") to 65.28 (2.570")	1-29/32"	48.00	1.8898"	7.9 (5/16")	8083174800	8083184800	8083274800
		48.42	1.9063"		8083174842	8083184842	8083274842
	49.00	1.9291"	8083174900		8083184900	8083274900	
	1-15/16"	49.21	1.9375"		8083174921	8083184921	8083274921
		50.00	1.9685"		8083175000	8083185000	8083275000
	1-31/32"	50.01	1.9688"		8083175001	8083185001	8083275001
		2"	50.80		2.0000"	8083175080	8083185080
	2-1/32"	51.00	2.0079"		8083175100	8083185100	8083275100
		51.59	2.0313"		8083175159	8083185159	8083275159
	2-3/64"	52.00	2.0472"		8083175200	8083185200	8083275200
		52.39	2.0625"		8083175239	8083185239	8083275239
	2-1/16"	53.00	2.0866"		8083175300	8083185300	8083275300
		53.18	2.0938"		8083175318	8083185318	8083275318
	2-3/32"	53.98	2.1250"		8083175398	8083185398	8083275398
		54.00	2.1260"		8083175400	8083185400	8083275400
	2-5/32"	54.79	2.1563"		8083175479	8083185479	8083275479
		55.00	2.1654"		8083175500	8083185500	8083275500
	2-3/16"	55.56	2.1875"		8083175556	8083185556	8083275556
		56.00	2.2047"		8083175600	8083185600	8083275600
	2-7/32"	56.36	2.2188"		8083175636	8083185636	8083275636
		57.00	2.2441"		8083175700	8083185700	8083275700
	2-1/4"	57.15	2.2500"		8083175715	8083185715	8083275715
		57.94	2.2813"		8083175794	8083185794	8083275794
	2-9/32"	58.00	2.2835"		8083175800	8083185800	8083275800
		58.74	2.3125"		8083175874	8083185874	8083275874
	2-5/16"	59.00	2.3228"		8083175900	8083185900	8083275900
		59.53	2.3438"		8083175953	8083185953	8083275953
	2-11/32"	60.00	2.3622"		8083176000	8083186000	8083276000
		60.33	2.3750"		8083176033	8083186033	8083276033
	2-3/8"	61.00	2.4016"		8083176100	8083186100	8083276100
		61.12	2.4063"		8083176112	8083186112	8083276112
	2-13/32"	61.91	2.4375"		8083176191	8083186191	8083276191
		62.00	2.4409"		8083176200	8083186200	8083276200
	2-7/16"	62.71	2.4688"		8083176271	8083186271	8083276271
		63.00	2.4803"		8083176300	8083186300	8083276300
	2-15/32"	63.50	2.5000"		8083176350	8083186350	8083276350
64.00		2.5197"	8083176400	8083186400	8083276400		
2-1/2"	64.29	2.5313"	8083176429	8083186429	8083276429		
	65.00	2.5591"	8083176500	8083186500	8083276500		
2-9/16"	65.09	2.5625"	8083176509	8083186509	8083276509		

SPADE Throw-Away Drill Inserts-HSS M48

- For use in high temperature alloys and materials with 350~500 Brinell.
- Reduce set-up time, it easily can be replaced on the machine.
- Any non-standard size available.



SERIES Y, Z, O

Series Min. to Max. (mm/inch)	Diameter			Thick Metric (mm/inch)	EDP No.		
	Inch (inch)	Metric (mm)	Decimal (inch)		TiN	TiCN	TiAlN
Y 9.50(.374") to 11.07(.436")	3/8"	9.50	.3740"	2.4 (3/32")	8093050950	8093070950	8093210950
		9.53	.3750"		8093050953	8093070953	8093210953
	25/64"	9.80	.3858"		8093050980	8093070980	8093210980
		9.92	.3906"		8093050992	8093070992	8093210992
		10.00	.3937"		8093051000	8093071000	8093211000
		10.20	.4016"		8093051020	8093071020	8093211020
	13/32"	10.32	.4062"		8093051032	8093071032	8093211032
		10.50	.4134"		8093051050	8093071050	8093211050
	27/64"	10.72	.4219"		8093051072	8093071072	8093211072
		10.80	.4252"		8093051080	8093071080	8093211080
	11.00	.4331"	8093051100	8093071100	8093211100		
Z 11.11(.437") to 12.95(.510")	7/16"	11.11	.4375"	2.4 (3/32")	8093051111	8093071111	8093211111
	29/64"	11.50	.4528"		8093051150	8093071150	8093211150
		11.51	.4531"		8093051151	8093071151	8093211151
	15/32"	11.91	.4688"		8093051191	8093071191	8093211191
		12.00	.4724"		8093051200	8093071200	8093211200
	31/64"	12.30	.4844"		8093051230	8093071230	8093211230
1/2"	12.50	.4921"	8093051250	8093071250	8093211250		
	12.70	.5000"	8093051270	8093071270	8093211270		
O 12.98 (.511") to 17.65 (.695")	33/64"	13.00	.5118"	3.2 (1/8")	8093051300	8093071300	8093211300
		13.10	.5156"		8093051310	8093071310	8093211310
	17/32"	13.49	.5312"		8093051349	8093071349	8093211349
		13.50	.5315"		8093051350	8093071350	8093211350
	35/64"	13.89	.5469"		8093051389	8093071389	8093211389
		14.00	.5512"		8093051400	8093071400	8093211400
	9/16"	14.29	.5625"		8093051429	8093071429	8093211429
		14.50	.5709"		8093051450	8093071450	8093211450
	37/64"	14.68	.5781"		8093051468	8093071468	8093211468
		15.00	.5906"		8093051500	8093071500	8093211500
	19/32"	15.08	.5938"		8093051508	8093071508	8093211508
		15.48	.6094"		8093051548	8093071548	8093211548
	39/64"	15.50	.6102"		8093051550	8093071550	8093211550
		15.88	.6250"		8093051588	8093071588	8093211588
	5/8"	16.00	.6299"		8093051600	8093071600	8093211600
		16.27	.6406"		8093051627	8093071627	8093211627
	41/64"	16.50	.6496"		8093051650	8093071650	8093211650
		16.67	.6562"		8093051667	8093071667	8093211667
21/32"	17.00	.6693"	8093051700	8093071700	8093211700		
	17.07	.6719"	8093051707	8093071707	8093211707		
43/64"	17.46	.6875"	8093051746	8093071746	8093211746		
	17.50	.6890"	8093051750	8093071750	8093211750		

SPADE Throw-Away Drill Inserts-HSS M48

- For use in high temperature alloys and materials with 350~500 Brinell.
- Reduce set-up time, it easily can be replaced on the machine.
- Any non-standard size available.



SERIES 1, 2

Series Min. to Max. (mm/inch)	Diameter			Thick Metric (mm/inch)	EDP No.		
	Inch (inch)	Metric (mm)	Decimal (inch)		TiN	TiCN	TiAlN
1 17.53 (.690") to 24.38 (.960")	45/64"	17.86	.7031"	4.0 (5/32")	8093051786	8093071786	8093211786
		18.00	.7087"		8093051800	8093071800	8093211800
	23/32"	18.26	.7188"		8093051826	8093071826	8093211826
		18.50	.7283"		8093051850	8093071850	8093211850
	47/64"	18.65	.7344"		8093051865	8093071865	8093211865
		19.00	.7480"		8093051900	8093071900	8093211900
	3/4"	19.05	.7500"		8093051905	8093071905	8093211905
	49/64"	19.45	.7656"		8093051945	8093071945	8093211945
		19.50	.7677"		8093051950	8093071950	8093211950
	25/32"	19.84	.7812"		8093051984	8093071984	8093211984
		20.00	.7874"		8093052000	8093072000	8093212000
	51/64"	20.24	.7969"		8093052024	8093072024	8093212024
		20.50	.8071"		8093052050	8093072050	8093212050
	13/16"	20.64	.8125"		8093052064	8093072064	8093212064
		21.00	.8268"		8093052100	8093072100	8093212100
	27/32"	21.43	.8438"		8093052143	8093072143	8093212143
	55/64"	21.83	.8594"		8093052183	8093072183	8093212183
		22.00	.8661"		8093052200	8093072200	8093212200
	7/8"	22.23	.8750"		8093052223	8093072223	8093212223
	57/64"	22.62	.8906"		8093052262	8093072262	8093212262
		23.00	.9055"		8093052300	8093072300	8093212300
	29/32"	23.02	.9062"		8093052302	8093072302	8093212302
59/64"	23.42	.9219"	8093052342	8093072342	8093212342		
15/16"	23.81	.9375"	8093052381	8093072381	8093212381		
	24.00	.9449"	8093052400	8093072400	8093212400		
2 24.41 (.961") to 35.05 (1.380")	31/32"	24.61	.9688"	4.8 (3/16")	8093052461	8093072461	8093212461
	63/64"	25.00	.9843"		8093052500	8093072500	8093212500
	1"	25.40	1.0000"		8093052540	8093072540	8093212540
	1-1/64"	25.80	1.0156"		8093052580	8093072580	8093212580
		26.00	1.0236"		8093052600	8093072600	8093212600
	1-1/32"	26.19	1.0312"		8093052619	8093072619	8093212619
	1-3/64"	26.59	1.0469"		8093052659	8093072659	8093212659
	1-1/16"	26.99	1.0625"		8093052699	8093072699	8093212699
		27.00	1.0630"		8093052700	8093072700	8093212700
	1-3/32"	27.78	1.0938"		8093052778	8093072778	8093212778
		28.00	1.1024"		8093052800	8093072800	8093212800
	1-7/64"	28.18	1.1094"		8093052818	8093072818	8093212818
	1-1/8"	28.58	1.1250"		8093052858	8093072858	8093212858
		29.00	1.1417"		8093052900	8093072900	8093212900
	1-5/32"	29.37	1.1562"		8093052937	8093072937	8093212937
		30.00	1.1811"		8093053000	8093073000	8093213000
	1-3/16"	30.16	1.1875"		8093053016	8093073016	8093213016
	1-7/32"	30.96	1.2188"		8093053096	8093073096	8093213096
		31.00	1.2205"		8093053100	8093073100	8093213100
	1-1/4"	31.75	1.2500"		8093053175	8093073175	8093213175
		32.00	1.2598"		8093053200	8093073200	8093213200
	1-9/32"	32.54	1.2812"		8093053254	8093073254	8093213254
	33.00	1.2992"	8093053300	8093073300	8093213300		
1-5/16"	33.34	1.3125"	8093053334	8093073334	8093213334		
	34.00	1.3386"	8093053400	8093073400	8093213400		
1-11/32"	34.13	1.3438"	8093053413	8093073413	8093213413		
1-3/8"	34.93	1.3750"	8093053493	8093073493	8093213493		
	35.00	1.3780"	8093053500	8093073500	8093213500		

SPADE Throw-Away Drill Inserts for Cast Iron-Carbide K10

- High performance on Gray cast iron over 220 Brinell, malleable cast iron with short chips, silicon aluminum and copper alloys.
- Reduce set-up time, it easily can be replaced on the machine.
- Any non-standard size available.



SERIES Y, Z, O

Series Min. to Max. (mm/inch)	Diameter			Thick Metric (mm/inch)	EDP No.		
	Inch (inch)	Metric (mm)	Decimal (inch)		TiN	TiCN	TiAlN
Y 9.50(.374") to 11.07(.436")		9.50	.3740"	2.4 (3/32")	8323080950	8323090950	8323230950
	3/8"	9.53	.3750"		8323080953	8323090953	8323230953
		9.80	.3858"		8323080980	8323090980	8323230980
	25/64"	9.92	.3906"		8323080992	8323090992	8323230992
		10.00	.3937"		8323081000	8323091000	8323231000
		10.20	.4016"		8323081020	8323091020	8323231020
	13/32"	10.32	.4062"		8323081032	8323091032	8323231032
		10.50	.4134"		8323081050	8323091050	8323231050
	27/64"	10.72	.4219"		8323081072	8323091072	8323231072
		10.80	.4252"		8323081080	8323091080	8323231080
	11.00	.4331"	8323081100	8323091100	8323231100		
Z 11.11(.437") to 12.95(.510")	7/16"	11.11	.4375"	2.4 (3/32")	8323081111	8323091111	8323231111
		11.50	.4528"		8323081150	8323091150	8323231150
	29/64"	11.51	.4531"		8323081151	8323091151	8323231151
	15/32"	11.91	.4688"		8323081191	8323091191	8323231191
		12.00	.4724"		8323081200	8323091200	8323231200
	31/64"	12.30	.4844"		8323081230	8323091230	8323231230
		12.50	.4921"		8323081250	8323091250	8323231250
	1/2"	12.70	.5000"		8323081270	8323091270	8323231270
		13.00	.5118"		8323081300	8323091300	8323231300
	33/64"	13.10	.5156"		8323081310	8323091310	8323231310
17/32"	13.49	.5312"	8323081349	8323091349	8323231349		
	13.50	.5315"	8323081350	8323091350	8323231350		
	13.89	.5469"	8323081389	8323091389	8323231389		
	14.00	.5512"	8323081400	8323091400	8323231400		
	14.29	.5625"	8323081429	8323091429	8323231429		
	14.50	.5709"	8323081450	8323091450	8323231450		
37/64"	14.68	.5781"	8323081468	8323091468	8323231468		
	15.00	.5906"	8323081500	8323091500	8323231500		
19/32"	15.08	.5938"	8323081508	8323091508	8323231508		
39/64"	15.48	.6094"	8323081548	8323091548	8323231548		
	15.50	.6102"	8323081550	8323091550	8323231550		
5/8"	15.88	.6250"	8323081588	8323091588	8323231588		
	16.00	.6299"	8323081600	8323091600	8323231600		
41/64"	16.27	.6406"	8323081627	8323091627	8323231627		
	16.50	.6496"	8323081650	8323091650	8323231650		
21/32"	16.67	.6562"	8323081667	8323091667	8323231667		
	17.00	.6693"	8323081700	8323091700	8323231700		
43/64"	17.07	.6719"	8323081707	8323091707	8323231707		
11/16"	17.46	.6875"	8323081746	8323091746	8323231746		
	17.50	.6890"	8323081750	8323091750	8323231750		

SPADE Throw-Away Drill Inserts for Cast Iron-Carbide K10

- High performance on Gray cast iron over 220 Brinell, malleable cast iron with short chips, silicon aluminum and copper alloys.
- Reduce set-up time, it easily can be replaced on the machine.
- Any non-standard size available.



SERIES 1, 2

Series Min. to Max. (mm/inch)	Diameter			Thick Metric (mm/inch)	EDP No.		
	Inch (inch)	Metric (mm)	Decimal (inch)		TiN	TiCN	TiAlN
1 17.53 (.690") to 24.38 (.960")	45/64"	17.86	.7031"	4.0 (5/32")	8323081786	8323091786	8323231786
		18.00	.7087"		8323081800	8323091800	8323231800
	23/32	18.26	.7188"		8323081826	8323091826	8323231826
		18.50	.7283"		8323081850	8323091850	8323231850
	47/64"	18.65	.7344"		8323081865	8323091865	8323231865
		19.00	.7480"		8323081900	8323091900	8323231900
	3/4"	19.05	.7500"		8323081905	8323091905	8323231905
	49/64"	19.45	.7656"		8323081945	8323091945	8323231945
		19.50	.7677"		8323081950	8323091950	8323231950
	25/32"	19.84	.7812"		8323081984	8323091984	8323231984
		20.00	.7874"		8323082000	8323092000	8323232000
	51/64"	20.24	.7969"		8323082024	8323092024	8323232024
		20.50	.8071"		8323082050	8323092050	8323232050
	13/16"	20.64	.8125"		8323082064	8323092064	8323232064
		21.00	.8268"		8323082100	8323092100	8323232100
	27/32"	21.43	.8438"		8323082143	8323092143	8323232143
	55/64"	21.83	.8594"		8323082183	8323092183	8323232183
		22.00	.8661"		8323082200	8323092200	8323232200
	7/8"	22.23	.8750"		8323082223	8323092223	8323232223
	57/64"	22.62	.8906"		8323082262	8323092262	8323232262
	23.00	.9055"	8323082300	8323092300	8323232300		
29/32"	23.02	.9062"	8323082302	8323092302	8323232302		
59/64"	23.42	.9219"	8323082342	8323092342	8323232342		
15/16"	23.81	.9375"	8323082381	8323092381	8323232391		
	24.00	.9449"	8323082400	8323092400	8323232400		
2 24.41 (.961") to 35.05 (1.380")	31/32"	24.61	.9688"	4.8 (3/16")	8323082461	8323092461	8323232461
	63/64"	25.00	.9843"		8323082500	8323092500	8323232500
	1"	25.40	1.0000"		8323082540	8323092540	8323232540
	1-1/64"	25.80	1.0156"		8323082580	8323092580	8323232580
		26.00	1.0236"		8323082600	8323092600	8323232600
	1-1/32"	26.19	1.0312"		8323082619	8323092619	8323232619
	1-3/64"	26.59	1.0469"		8323082659	8323092659	8323232659
	1-1/16"	26.99	1.0625"		8323082699	8323092699	8323232699
		27.00	1.0630"		8323082700	8323092700	8323232700
	1-3/32"	27.78	1.0938"		8323082778	8323092778	8323232778
		28.00	1.1024"		8323082800	8323092800	8323232800
	1-7/64"	28.18	1.1094"		8323082818	8323092818	8323232818
	1-1/8"	28.58	1.1250"		8323082858	8323092858	8323232858
		29.00	1.1417"		8323082900	8323092900	8323232900
	1-5/32"	29.37	1.1562"		8323082937	8323092937	8323232937
		30.00	1.1811"		8323083000	8323093000	8323233000
	1-3/16"	30.16	1.1875"		8323083016	8323093016	8323233016
	1-7/32"	30.96	1.2188"		8323083096	8323093096	8323233096
		31.00	1.2205"		8323083100	8323093100	8323233100
	1-1/4"	31.75	1.2500"		8323083175	8323093175	8323233175
	32.00	1.2598"	8323083200	8323093200	8323233200		
1-9/32"	32.54	1.2812"	8323083254	8323093254	8323233254		
	33.00	1.2992"	8323083300	8323093300	8323233300		
1-5/16"	33.34	1.3125"	8323083334	8323093334	8323233334		
	34.00	1.3386"	8323083400	8323093400	8323233400		
1-11/32"	34.13	1.3438"	8323083413	8323093413	8323233413		
1-3/8"	34.93	1.3750"	8323083493	8323093493	8323233493		
	35.00	1.3780"	8323083500	8323093500	8323233500		

SPADE Throw-Away Drill Inserts -Carbide K20

- For use in Gray cast iron up to 220 Brinell, nonferrous metals, copper, brass and aluminum.
- Reduce set-up time, it easily can be replaced on the machine.
- Any non-standard size available.



SERIES Y, Z, O

Series Min. to Max. (mm/inch)	Diameter			Thick Metric (mm/inch)	EDP No.		
	Inch (inch)	Metric (mm)	Decimal (inch)		TiN	TiCN	TiAlN
Y 9.50(.374") to 11.07(.436")	3/8"	9.50	.3740"	2.4 (3/32")	8303080950	8303090950	8303230950
		9.53	.3750"		8303080953	8303090953	8303230953
	25/64"	9.80	.3858"		8303080980	8303090980	8303230980
		9.92	.3906"		8303080992	8303090992	8303230992
	13/32"	10.00	.3937"		8303081000	8303091000	8303231000
		10.20	.4016"		8303081020	8303091020	8303231020
		10.32	.4062"		8303081032	8303091032	8303231032
		10.50	.4134"		8303081050	8303091050	8303231050
27/64"	10.72	.4219"	8303081072	8303091072	8303231072		
	10.80	.4252"	8303081080	8303091080	8303231080		
	11.00	.4331"	8303081100	8303091100	8303231100		
Z 11.11(.437") to 12.95(.510")	7/16"	11.11	.4375"	2.4 (3/32")	8303081111	8303091111	8303231111
	29/64"	11.50	.4528"		8303081150	8303091150	8303231150
		11.51	.4531"		8303081151	8303091151	8303231151
	15/32"	11.91	.4688"		8303081191	8303091191	8303231191
	31/64"	12.00	.4724"		8303081200	8303091200	8303231200
		12.30	.4844"		8303081230	8303091230	8303231230
1/2"	12.50	.4921"	8303081250	8303091250	8303231250		
	12.70	.5000"	8303081270	8303091270	8303231270		
O 12.98 (.511") to 17.65 (.695")	33/64"	13.00	.5118"	3.2 (1/8")	8303081300	8303091300	8303231300
		13.10	.5156"		8303081310	8303091310	8303231310
	17/32"	13.49	.5312"		8303081349	8303091349	8303231349
	35/64"	13.50	.5315"		8303081350	8303091350	8303231350
		13.89	.5469"		8303081389	8303091389	8303231389
	9/16"	14.00	.5512"		8303081400	8303091400	8303231400
		14.29	.5625"		8303081429	8303091429	8303231429
	37/64"	14.50	.5709"		8303081450	8303091450	8303231450
		14.68	.5781"		8303081468	8303091468	8303231480
		15.00	.5906"		8303081500	8303091500	8303231500
	19/32"	15.08	.5938"		8303081508	8303091508	8303231508
	39/64"	15.48	.6094"		8303081548	8303091548	8303231548
	5/8"	15.50	.6102"		8303081550	8303091550	8303231550
		15.88	.6250"		8303081588	8303091588	8303231588
	16.00	.6299"	8303081600	8303091600	8303231600		
41/64"	16.27	.6406"	8303081627	8303091627	8303231627		
21/32"	16.50	.6496"	8303081650	8303091650	8303231650		
	16.67	.6562"	8303081667	8303091667	8303231667		
	17.00	.6693"	8303081700	8303091700	8303231700		
43/64"	17.07	.6719"	8303081707	8303091707	8303231707		
11/16"	17.46	.6875"	8303081746	8303091746	8303231746		
	17.50	.6890"	8303081750	8303091750	8303231750		

SPADE Throw-Away Drill Inserts -Carbide K20

- For use in Gray cast iron up to 220 Brinell, nonferrous metals, copper, brass and aluminum.
- Reduce set-up time, it easily can be replaced on the machine.
- Any non-standard size available.



SERIES 1, 2

Series Min. to Max. (mm/inch)	Diameter			Thick Metric (mm/inch)	EDP No.		
	Inch (inch)	Metric (mm)	Decimal (inch)		TiN	TiCN	TiAlN
1 17.53 (.690") to 24.38 (.960")	45/64"	17.86	.7031"	4.0 (5/32")	8303081786	8303091786	8303231786
		18.00	.7087"		8303081800	8303091800	8303231800
	23/32"	18.26	.7188"		8303081826	8303091826	8303231826
		18.50	.7283"		8303081850	8303091850	8303231850
	47/64"	18.65	.7344"		8303081865	8303091865	8303231865
		19.00	.7480"		8303081900	8303091900	8303231900
	3/4"	19.05	.7500"		8303081905	8303091905	8303231905
	49/64"	19.45	.7656"		8303081945	8303091945	8303231945
		19.50	.7677"		8303081950	8303091950	8303231950
	25/32"	19.84	.7812"		8303081984	8303091984	8303231984
		20.00	.7874"		8303082000	8303092000	8303232000
	51/64"	20.24	.7969"		8303082024	8303092024	8303232024
		20.50	.8071"		8303082050	8303092050	8303232050
	13/16"	20.64	.8125"		8303082064	8303092064	8303232064
		21.00	.8268"		8303082100	8303092100	8303232100
	27/32"	21.43	.8438"		8303082143	8303092143	8303232143
	55/64"	21.83	.8594"		8303082183	8303092183	8303232183
		22.00	.8661"		8303082200	8303092200	8303232200
	7/8"	22.23	.8750"		8303082223	8303092223	8303232223
	57/64"	22.62	.8906"		8303082262	8303092262	8303232262
	23.00	.9055"	8303082300	8303092300	8303232300		
29/32"	23.02	.9062"	8303082302	8303092302	8303232302		
59/64"	23.42	.9219"	8303082342	8303092342	8303232342		
15/16"	23.81	.9375"	8303082381	8303092381	8303232381		
	24.00	.9449"	8303082400	8303092400	8303232400		
2 24.41 (.961") to 35.05 (1.380")	31/32"	24.61	.9688"	4.8 (3/16")	8303082461	8303092461	8303232461
	63/64"	25.00	.9843"		8303082500	8303092500	8303232500
	1"	25.40	1.0000"		8303082540	8303092540	8303232540
	1-1/64"	25.80	1.0156"		8303082580	8303092580	8303232580
		26.00	1.0236"		8303082600	8303092600	8303232600
	1-1/32"	26.19	1.0312"		8303082619	8303092619	8303232619
	1-3/64"	26.59	1.0469"		8303082659	8303092659	8303232659
	1-1/16"	26.99	1.0625"		8303082699	8303092699	8303232699
		27.00	1.0630"		8303082700	8303092700	8303232700
	1-3/32"	27.78	1.0938"		8303082778	8303092778	8303232778
		28.00	1.1024"		8303082800	8303092800	8303232800
	1-7/64"	28.18	1.1094"		8303082818	8303092818	8303232818
	1-1/8"	28.58	1.1250"		8303082858	8303092858	8303232858
		29.00	1.1417"		8303082900	8303092900	8303232900
	1-5/32"	29.37	1.1562"		8303082937	8303092937	8303232937
		30.00	1.1811"		8303083000	8303093000	8303233000
	1-3/16"	30.16	1.1875"		8303083016	8303093016	8303233016
	1-7/32"	30.96	1.2188"		8303083096	8303093096	8303233096
		31.00	1.2205"		8303083100	8303093100	8303233100
	1-1/4"	31.75	1.2500"		8303083175	8303093175	8303233175
	32.00	1.2598"	8303083200	8303093200	8303233200		
1-9/32"	32.54	1.2812"	8303083254	8303093254	8303233254		
	33.00	1.2992"	8303083300	8303093300	8303233300		
1-5/16"	33.34	1.3125"	8303083334	8303093334	8303233334		
	34.00	1.3386"	8303083400	8303093400	8303233400		
1-11/32"	34.13	1.3438"	8303083413	8303093413	8303233413		
1-3/8"	34.93	1.3750"	8303083493	8303093493	8303233493		
	35.00	1.3780"	8303083500	8303093500	8303233500		

SPADE Throw-Away Drill Inserts -Carbide K20

- For use in Gray cast iron up to 220 Brinell, nonferrous metals, copper, brass and aluminum.
- Reduce set-up time, it easily can be replaced on the machine.
- Any non-standard size available.



SERIES 3

Series Min. to Max. (mm/inch)	Diameter			Thick Metric (mm/inch)	EDP No.		
	Inch (inch)	Metric (mm)	Decimal (inch)		TiN	TiCN	TiAlN
3 34.37 (1.353") to 47.80 (1.882")	1-13/32"	35.72	1.4062"	6.4 (1/4")	8303083572	8303093572	8303233572
		36.00	1.4173"		8303083600	8303093600	8303233600
	1-7/16"	36.51	1.4375"		8303083651	8303093651	8303233651
		37.00	1.4567"		8303083700	8303093700	8303233700
	1-15/32"	37.31	1.4688"		8303083731	8303093731	8303233731
		38.00	1.4961"		8303083800	8303093800	8303233800
	1-1/2"	38.10	1.5000"		8303083810	8303093810	8303233810
	1-17/32"	38.89	1.5312"		8303083889	8303093889	8303233889
		39.00	1.5354"		8303083900	8303093900	8303233900
	1-9/16"	39.69	1.5625"		8303083969	8303093969	8303233969
		40.00	1.5748"		8303084000	8303094000	8303234000
	1-19/32"	40.48	1.5938"		8303084048	8303094048	8303234048
		41.00	1.6142"		8303084100	8303094100	8303234100
	1-5/8"	41.28	1.6250"		8303084128	8303094128	8303234128
		42.00	1.6535"		8303084200	8303094200	8303234200
	1-21/32"	42.07	1.6562"		8303084207	8303094207	8303234207
	1-11/16"	42.86	1.6875"		8303084286	8303094286	8303234286
		43.00	1.6929"		8303084300	8303094300	8303234300
	1-23/32"	43.66	1.7188"		8303084366	8303094366	8303234366
		44.00	1.7323"		8303084400	8303094400	8303234400
1-3/4"	44.45	1.7500"	8303084445	8303094445	8303234445		
	45.00	1.7717"	8303084500	8303094500	8303234500		
1-25/32"	45.24	1.7812"	8303084524	8303094524	8303234524		
	46.00	1.8110"	8303084600	8303094600	8303234600		
1-13/16"	46.04	1.8125"	8303084604	8303094604	8303234604		
1-27/32"	46.83	1.8438"	8303084683	8303094683	8303234683		
	47.00	1.8504"	8303084700	8303094700	8303234700		
1-7/8"	47.63	1.8750"	8303084763	8303094763	8303234763		



SPADE Throw-Away Drill Inserts -Carbide P40

- For general use in carbon steels and alloys steels.
- Reduce set-up time, it easily can be replaced on the machine.
- Any non-standard size available.



SERIES Y, Z, O

Series Min. to Max. (mm/inch)	Diameter			Thick Metric (mm/inch)	EDP No.				
	Inch (inch)	Metric (mm)	Decimal (inch)		TiN	TiCN	TiAlN		
Y 9.50 (.374 ") to 11.07 (.436 ")	3/8 "	9.50	.3740"	2.4 (3/32 ")	8313080950	8313090950	8313230950		
		9.53	.3750"		8313080953	8313090953	8313230953		
	25/64 "	9.80	.3858"		8313080980	8313090980	8313230980		
		9.92	.3906"		8313080992	8313090992	8313230992		
		10.00	.3937"		8313081000	8313091000	8313231000		
		10.20	.4016"		8313081020	8313091020	8313231020		
	13/32 "	10.32	.4062"		8313081032	8313091032	8313231032		
		10.50	.4134"		8313081050	8313091050	8313231050		
	27/64 "	10.72	.4219"		8313081072	8313091072	8313231072		
		10.80	.4252"		8313081080	8313091080	8313231080		
	11.00	.4331"	8313081100	8313091100	8313231100				
Z 11.11(.437 ") to 12.95(.510 ")	7/16 "	11.11	.4375"	2.4 (3/32 ")	8313081111	8313091111	8313231111		
		11.50	.4528"		8313081150	8313091150	8313231150		
	29/64 "	11.51	.4531"		8313081151	8313091151	8313231151		
		11.91	.4688"		8313081191	8313091191	8313231191		
		12.00	.4724"		8313081200	8313091200	8313231200		
		12.30	.4844"		8313081230	8313091230	8313231230		
	31/64 "	12.50	.4921"		8313081250	8313091250	8313231250		
		12.70	.5000"		8313081270	8313091270	8313231270		
	O 12.98 (.511 ") to 17.65 (.695 ")	33/64 "	13.00		.5118"	3.2 (1/8 ")	8313081300	8313091300	8313231300
			13.10		.5156"		8313081310	8313091310	8313231310
17/32 "		13.49	.5312"	8313081349	8313091349		8313231349		
		13.50	.5315"	8313081350	8313091350		8313231350		
35/64 "		13.89	.5469"	8313081389	8313091389		8313231389		
		14.00	.5512"	8313081400	8313091400		8313231400		
9/16 "		14.29	.5625"	8313081429	8313091429		8313231429		
		14.50	.5709"	8313081450	8313091450		8313231450		
37/64 "		14.68	.5781"	8313081468	8313091468		8313231468		
		15.00	.5906"	8313081500	8313091500		8313231500		
	19/32 "	15.08	.5938"	8313081508	8313091508	8313231508			
		15.48	.6094"	8313081548	8313091548	8313231548			
	39/64 "	15.50	.6102"	8313081550	8313091550	8313231550			
		15.88	.6250"	8313081588	8313091588	8313231588			
	5/8 "	16.00	.6299"	8313081600	8313091600	8313231600			
		16.27	.6406"	8313081627	8313091627	8313231627			
		16.50	.6496"	8313081650	8313091650	8313231650			
		16.67	.6562"	8313081667	8313091667	8313231667			
	21/32 "	17.00	.6693"	8313081700	8313091700	8313231700			
		17.07	.6719"	8313081707	8313091707	8313231707			
43/64 "	17.46	.6875"	8313081746	8313091746	8313231746				
	17.50	.6890"	8313081750	8313091750	8313231750				

SPADE Throw-Away Drill Inserts -Carbide P40

- For general use in carbon steels and alloys steels.
- Reduce set-up time, it easily can be replaced on the machine.
- Any non-standard size available.



SERIES 1, 2

Series Min. to Max. (mm/inch)	Diameter			Thick Metric (mm/inch)	EDP No.		
	Inch (inch)	Metric (mm)	Decimal (inch)		TiN	TiCN	TiAlN
1 17.53 (.690 ") to 24.38 (.960 ")	45/64 "	17.86	.7031"	4.0 (5/32 ")	8313081786	8313091786	8313231786
		18.00	.7087"		8313081800	8313091800	8313231800
	23/32 "	18.26	.7188"		8313081826	8313091826	8313231826
		18.50	.7283"		8313081850	8313091850	8313231850
	47/64 "	18.65	.7344"		8313081865	8313091865	8313231865
		19.00	.7480"		8313081900	8313091900	8313231900
	3/4 "	19.05	.7500"		8313081905	8313091905	8313231905
		19.45	.7656"		8313081945	8313091945	8313231945
	49/64 "	19.50	.7677"		8313081950	8313091950	8313231950
		19.84	.7812"		8313081984	8313091984	8313231984
	25/32 "	20.00	.7874"		8313082000	8313092000	8313232000
		20.24	.7969"		8313082024	8313092024	8313232024
	51/64 "	20.50	.8071"		8313082050	8313092050	8313232050
		20.64	.8125"		8313082064	8313092064	8313232064
	13/16 "	21.00	.8268"		8313082100	8313092100	8313232100
		21.43	.8438"		8313082143	8313092143	8313232143
	27/32 "	21.83	.8594"		8313082183	8313092183	8313232183
		22.00	.8661"		8313082200	8313092200	8313232200
	7/8 "	22.23	.8750"		8313082223	8313092223	8313232223
		22.62	.8906"		8313082262	8313092262	8313232262
57/64 "	23.00	.9055"	8313082300	8313092300	8313232300		
	23.02	.9062"	8313082302	8313092302	8313232302		
29/32 "	23.42	.9219"	8313082342	8313092342	8313232342		
	23.81	.9375"	8313082381	8313092381	8313232381		
59/64 "	24.00	.9449"	8313082400	8313092400	8313232400		
	24.61	.9688"	8313082461	8313092461	8313232461		
2 24.41 (.961 ") to 35.05 (1.380 ")	31/32 "	25.00	.9843"	4.8 (3/16 ")	8313082500	8313092500	8313232500
		25.40	1.0000"		8313082540	8313092540	8313232540
	63/64 "	25.80	1.0156"		8313082580	8313092580	8313232580
		26.00	1.0236"		8313082600	8313092600	8313232600
	1 "	26.19	1.0312"		8313082619	8313092619	8313232619
		26.59	1.0469"		8313082659	8313092659	8313232659
	1-1/64 "	26.99	1.0625"		8313082699	8313092699	8313232699
		27.00	1.0630"		8313082700	8313092700	8313232700
	1-1/32 "	27.78	1.0938"		8313082778	8313092778	8313232778
		28.00	1.1024"		8313082800	8313092800	8313232800
	1-3/64 "	28.18	1.1094"		8313082818	8313092818	8313232818
		28.58	1.1250"		8313082858	8313092858	8313232858
	1-1/8 "	29.00	1.1417"		8313082900	8313092900	8313232900
		29.37	1.1562"		8313082937	8313092937	8313232937
	1-5/32 "	30.00	1.1811"		8313083000	8313093000	8313233000
		30.16	1.1875"		8313083016	8313093016	8313233016
	1-3/16 "	30.96	1.2188"		8313083096	8313093096	8313233096
		31.00	1.2205"		8313083100	8313093100	8313233100
	1-7/32 "	31.75	1.2500"		8313083175	8313093175	8313233175
		32.00	1.2598"		8313083200	8313093200	8313233200
1-1/4 "	32.54	1.2812"	8313083254	8313093254	8313233254		
	33.00	1.2992"	8313083300	8313093300	8313233300		
1-9/32 "	33.34	1.3125"	8313083334	8313093334	8313233334		
	34.00	1.3386"	8313083400	8313093400	8313233400		
1-5/16 "	34.13	1.3438"	8313083413	8313093413	8313233413		
	34.93	1.3750"	8313083493	8313093493	8313233493		
1-11/32 "	35.00	1.3780"	8313083500	8313093500	8313233500		

SPADE Throw-Away Drill Inserts -Carbide P40

- For general use in carbon steels and alloys steels.
- Reduce set-up time, it easily can be replaced on the machine.
- Any non-standard size available.



SERIES 3

Series Min. to Max. (mm/inch)	Diameter			Thick Metric (mm/inch)	EDP No.		
	Inch (inch)	Metric (mm)	Decimal (inch)		TiN	TiCN	TiAlN
3 34.37 (1.353") to 47.80 (1.882")	1-13/32"	35.72	1.4062"	6.4 (1/4")	8313083572	8313093572	8313233572
		36.00	1.4173"		8313083600	8313093600	8313233600
	1-7/16"	36.51	1.4375"		8313083651	8313093651	8313233651
		37.00	1.4567"		8313083700	8313093700	8313233700
	1-15/32"	37.31	1.4688"		8313083731	8313093731	8313233731
		38.00	1.4961"		8313083800	8313093800	8313233800
	1-1/2"	38.10	1.5000"		8313083810	8313093810	8313233810
		38.89	1.5312"		8313083889	8313093889	8313233889
	1-17/32"	39.00	1.5354"		8313083900	8313093900	8313233900
		39.69	1.5625"		8313083969	8313093969	8313233969
	1-9/16"	40.00	1.5748"		8313084000	8313094000	8313234000
		40.48	1.5938"		8313084048	8313094048	8313234048
	1-19/32"	41.00	1.6142"		8313084100	8313094100	8313234100
		41.28	1.6250"		8313084128	8313094128	8313234128
	1-5/8"	42.00	1.6535"		8313084200	8313094200	8313234200
		42.07	1.6562"		8313084207	8313094207	8313234207
	1-21/32"	42.86	1.6875"		8313084286	8313094286	8313234286
		43.00	1.6929"		8313084300	8313094300	8313234300
	1-11/16"	43.66	1.7188"		8313084366	8313094366	8313234366
		44.00	1.7323"		8313084400	8313094400	8313234400
	1-3/4"	44.45	1.7500"		8313084445	8313094445	8313234445
		45.00	1.7717"		8313084500	8313094500	8313234500
	1-25/32"	45.24	1.7812"		8313084524	8313094524	8313234524
		46.00	1.8110"		8313084600	8313094600	8313234600
	1-13/16"	46.04	1.8125"		8313084604	8313094604	8313234604
		46.83	1.8438"		8313084683	8313094683	8313234683
	1-27/32"	47.00	1.8504"		8313084700	8313094700	8313234700
		47.63	1.8750"		8313084763	8313094763	8313234763

RECOMMENDED CUTTING CONDITIONS-HSS

Material	Material Hardness		* HSS Grade	Speed (M/min)	Feed (mm/rev)						
	(Bhn)	(HRc)			φ9.5 ~12.5	φ13 ~17.5	φ18 ~24	φ25 ~35	φ36 ~47	φ48 ~65	φ66 ~114
Free machining Steel 1213, 12L13, 1215 12L14, 1118 etc	100 - 150	0	HSS	84	0.16	0.23	0.31	0.40	0.48	0.55	0.67
	150 - 200	0 - 13	HSS	81	0.16	0.23	0.31	0.40	0.48	0.55	0.67
	200 - 250	13 - 24	HSS	72	0.14	0.23	0.31	0.38	0.48	0.57	0.69
Low Carbon Steel 1015, 1020, 1140 1025 etc	85 - 125	0	HSS	75	0.15	0.22	0.28	0.37	0.46	0.56	0.67
	125 - 175	0 - 7	HSS	72	0.15	0.22	0.28	0.37	0.46	0.56	0.67
	175 - 225	7 - 20	HSS	69	0.13	0.19	0.24	0.34	0.43	0.50	0.57
Medium Carbon Steel 1035, 1050, 1045 1055, 1140 etc	125 - 175	0 - 7	HSS	75	0.14	0.22	0.28	0.35	0.45	0.55	0.65
	175 - 225	7 - 20	HSS	69	0.13	0.19	0.23	0.34	0.43	0.50	0.58
	225 - 275	20 - 28	HSS	63	0.13	0.19	0.23	0.34	0.43	0.50	0.58
Structural Steel A36, A516, A182 etc	100 - 150	0	HSS	63	0.14	0.23	0.29	0.35	0.44	0.50	0.63
	150 - 250	0 - 24	HSS	55	0.13	0.22	0.24	0.28	0.38	0.46	0.59
	250 - 350	24 - 37	SH, PH	41	0.10	0.20	0.22	0.24	0.34	0.40	0.48
Cast Iron / S,G Iron A48-76 GR30/GR45 A536-72 60-40-18 A220-76 GR40010 etc	120 - 150	0	HSS	75	0.16	0.30	0.40	0.49	0.59	0.69	0.75
	150 - 200	0 - 13	HSS	70	0.14	0.26	0.35	0.45	0.56	0.64	0.68
	200 - 220	13 - 19	HSS	58	0.14	0.23	0.30	0.41	0.46	0.52	0.60
	220 - 260	19 - 26	SH, PH	52	0.13	0.17	0.23	0.30	0.35	0.43	0.50
Alloy Steel 8620, 4130, 4137 4140, 6150 etc	125 - 175	0 - 7	HSS	63	0.15	0.20	0.24	0.36	0.43	0.47	0.53
	175 - 225	7 - 20	HSS	58	0.13	0.20	0.24	0.36	0.42	0.46	0.55
	225 - 275	20 - 28	HSS	56	0.13	0.16	0.23	0.35	0.41	0.44	0.55
	275 - 325	28 - 34	SH, PH	53	0.09	0.15	0.22	0.28	0.38	0.41	0.50
Tool Steel H13, H21, A2, S1 etc	325 - 375	34 - 40	SH, PH	46	0.08	0.15	0.21	0.27	0.38	0.40	0.51
	150 - 200	0 - 13	SH	34	0.09	0.15	0.19	0.25	0.28	0.36	0.41
	200 - 250	13 - 24	SH, PH	26	0.09	0.15	0.19	0.25	0.28	0.36	0.41
High Temp. Alloy Hastelloy B, Inconel etc	140 - 220	0 - 19	SH, PH	12	0.08	0.17	0.20	0.24	0.30	0.37	-
	220 - 310	19 - 33	PH	11	0.08	0.14	0.18	0.19	0.25	0.29	-
High Strength Alloy 9840, 4340, 4330V etc	225 - 300	0 - 32	SH, PH	35	0.13	0.18	0.23	0.24	0.36	0.43	0.50
	300 - 350	32 - 37	SH, PH	27	0.10	0.18	0.23	0.24	0.36	0.43	0.50
	350 - 400	37 - 43	PH	21	0.08	0.15	0.20	0.22	0.30	0.48	0.46
Aluminium 2014, 6061, 7075 etc	30	0	HSS	244	0.19	0.33	0.41	0.50	0.54	0.64	0.62
	180	0 - 8	HSS	137	0.19	0.33	0.41	0.46	0.54	0.64	0.62
Stainless Steel 310, 316, 410, 330 etc	135 - 185	0 - 9	HSS	34	0.14	0.20	0.23	0.26	0.36	0.41	0.50
	185 - 275	9 - 28	HSS	29	0.12	0.18	0.20	0.24	0.30	0.36	0.46

RPM = revolution per minute (rev/min)
M/min = surface meter per minute(M/min)
DIA = diameter of drill (mm)
mm/rev = feed rate(mm/rev)

*** Formulas :**

$$M/min = \frac{(RPM) \cdot (\pi) \cdot (DIA.)}{1000}$$

$$mm/min = (RPM) \cdot (mm/rev)$$

$$RPM = \frac{(M/min) \cdot (1000)}{(\pi) \cdot (DIA.)}$$

* **HSS Grade** : HSS = HSS M4, **SH** = Super HSS T15, **PH** = Premium HSS M48
 The recommendations for speeds, feeds and other parameters presented in this chart are nominal recommendations and should be considered only as good starting points.
 Speed and feed reductions (20% reduction in speed and 10% reduction in feed) are recommended.

RECOMMENDED CUTTING CONDITIONS-CARBIDE

Material	Material Hardness		CARBIDE Grade	Speed (M/min)	Feed (mm/rev)				
	(Bhn)	(HRc)			ø 9.5 ~12.5	ø 13 ~17.5	ø 18 ~24	ø 25 ~35	ø 36 ~47
Free machining Steel	100 - 150	0	P40	125	0.13	0.21	0.29	0.36	0.47
12L13, 12L13, 1215	150 - 200	0 - 13	P40	110	0.13	0.19	0.27	0.31	0.42
12L14, 1118 etc	200 - 250	13 - 24	P40	101	0.12	0.18	0.24	0.29	0.38
Low Carbon Steel	85 - 125	0	P40	119	0.15	0.19	0.25	0.35	0.45
1015, 1020, 1140	125 - 175	0 - 7	P40	107	0.13	0.19	0.24	0.34	0.44
1025 etc	175 - 225	7 - 20	P40	96	0.10	0.17	0.20	0.30	0.41
	225 - 275	20 - 28	P40	84	0.10	0.17	0.19	0.29	0.37
Medium Carbon Steel	125 - 175	0 - 7	P40	102	0.12	0.19	0.24	0.34	0.42
1035, 1050, 1045	175 - 225	7 - 20	P40	93	0.11	0.17	0.20	0.30	0.40
1055, 1140 etc	225 - 275	20 - 28	P40	84	0.10	0.17	0.19	0.29	0.38
	275 - 325	28 - 34	P40	67	0.10	0.14	0.16	0.25	0.35
Structural Steel	100 - 150	0	P40	91	0.14	0.23	0.27	0.29	0.40
A36, A516, A182 etc	150 - 250	0 - 24	P40	75	0.13	0.19	0.24	0.26	0.38
	250 - 350	24 - 37	P40	73	0.10	0.17	0.20	0.22	0.32
Cast Iron / S,G Iron	120 - 150	0	K20,K10	137	0.13	0.22	0.27	0.37	0.48
A48-76 GR30/GR45	150 - 200	0 - 13	K20,K10	125	0.12	0.20	0.25	0.35	0.46
A536-72 60-40-18	200 - 220	13 - 19	K20,K10	111	0.12	0.18	0.20	0.31	0.35
A220-76 GR40010 etc	220 - 260	19 - 26	K20,K10	93	0.10	0.15	0.17	0.24	0.33
	260 - 320	26 - 34	K20,K10	79	0.10	0.14	0.14	0.20	0.27
Alloy Steel	125 - 175	0 - 7	P40	98	0.13	0.20	0.24	0.31	0.39
8620, 4130, 4137	175 - 225	7 - 20	P40	88	0.13	0.19	0.22	0.30	0.37
4140, 6150 etc	225 - 275	20 - 28	P40	81	0.10	0.18	0.21	0.29	0.36
	275 - 325	28 - 34	P40	78	0.09	0.15	0.20	0.28	0.35
	325 - 375	34 - 40	P40	64	0.08	0.13	0.19	0.24	0.33
Tool Steel	150 - 200	0 - 13	P40	67	0.07	0.12	0.17	0.22	0.27
H13, H21, A2, S1 etc	200 - 250	13 - 24	P40	50	0.07	0.12	0.16	0.21	0.26
High Temp. Alloy	140 - 220	0 - 19	K20	30	0.08	0.32	0.17	0.22	0.26
Hastelloy B, Inconel etc	220 - 310	19 - 33	K20	24	0.08	0.28	0.15	0.19	0.23
High Strength Alloy	225 - 300	0 - 32	P40	62	0.13	0.18	0.19	0.23	0.34
9840, 4340, 4330V etc	300 - 350	32 - 37	P40	55	0.10	0.15	0.18	0.22	0.30
	350 - 400	37 - 43	P40	47	0.08	0.13	0.15	0.19	0.24
Aluminium	30	0	K20	427	0.19	0.32	0.40	0.47	0.52
2014, 6061, 7075 etc	180	0 - 8	K20	291	0.17	0.27	0.34	0.45	0.49
Stainless Steel	135 - 185	0 - 9	K20	62	0.14	0.20	0.22	0.26	0.32
310, 316, 410, 330 etc	185 - 275	9 - 28	K20	46	0.12	0.18	0.19	0.24	0.28

RPM = revolution per minute (rev/min)
M/min = surface meter per minute(M/min)
DIA = diameter of drill (mm)
mm/rev = feed rate(mm/rev)

*** Formulas :**

$$M/min = \frac{(RPM) \cdot (\pi) \cdot (DIA.)}{1000}$$

$$mm/min = (RPM) \cdot (mm/rev)$$

$$RPM = \frac{(M/min) \cdot (1000)}{(\pi) \cdot (DIA.)}$$

The recommendations for speeds, feeds and other parameters presented in this chart are nominal recommendations and should be considered only as good starting points.
 Speed and feed reductions (20% reduction in speed and 10% reduction in feed) are recommended.



Taper Shank Holders

Flanged Straight Shank Holders

Straight Shank Holders

Holder Accessories

Drill Insert Holders Designation System

TAPER SHANK HOLDER SHORT LENGTH - Straight Flute

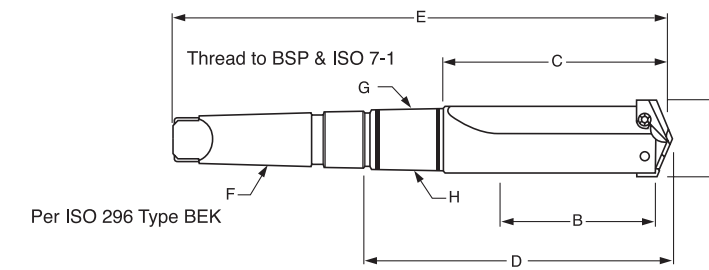

Series	EDP No.	A	B	C	D	E	F	G	H
		Drill Insert Range	Max. Drill Depth	Flute Length	Ref. Length	Overall Length	MT	Pipe Tap	RCA
Y	8Y2150002M	9.5 ~ 11.0	31.7	51.5	88.0	160.3	#2	1/16"	PR120190
Z	8Z2150002M	11.5 ~ 12.5	31.7	51.5	88.0	160.3	#2	1/16"	PR120190
0	802150002M	13.0 ~ 17.5	34.9	55.5	92.4	164.3	#2	1/16"	PR120190
0.5	812150002M	15.5 ~ 17.5	34.9	55.5	92.4	164.3	#2	1/16"	PR120190
1	822150003M	18.0 ~ 24.0	69.8	98.4	142.5	232.5	#3	1/8"	PR120254
1.5	832150003M	22.0 ~ 24.0	69.8	98.4	142.5	232.5	#3	1/8"	PR120254
2	842150004M	25.0 ~ 35.0	85.7	114.3	160.4	273.8	#4	1/8"	PR120254
2.5	852150004M	30.0 ~ 35.0	85.7	114.3	167.6	281.0	#4	1/4"	PR120317
3	862150004M	36.0 ~ 47.0	120.6	152.4	206.4	319.1	#4	1/4"	PR120317
4	872150005M	48.0 ~ 65.0	130.1	165.1	219.1	363.5	#5	1/4"	PR120444
5	882150005M	64.0 ~ 88.0	171.1	215.9	287.3	430.2	#5	1/2"	PR120571
7	892150005M	90.0 ~ 114.0	171.1	225.4	296.8	439.7	#5	1/2"	PR120571

TAPER SHANK HOLDER INTERMEDIATE LENGTH - Spiral Flute

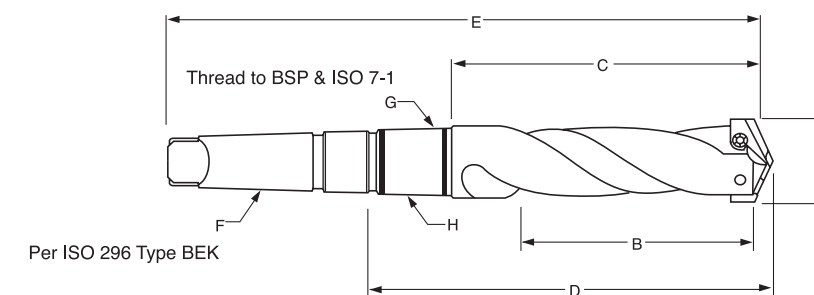

Series	EDP No.	A	B	C	D	E	F	G	H
		Drill Insert Range	Max. Drill Depth	Flute Length	Ref. Length	Overall Length	MT	Pipe Tap	RCA
1	823250003M	18.0 ~ 24.0	120.7	149.2	193.3	283.3	#3	1/8"	PR120254
1.5	833250003M	22.0 ~ 24.0	120.7	149.2	193.3	283.3	#3	1/8"	PR120254
2	843250004M	25.0 ~ 35.0	136.5	165.1	211.2	324.6	#4	1/8"	PR120254
2.5	853250004M	30.0 ~ 35.0	136.5	165.1	218.4	331.8	#4	1/4"	PR120317
3	863250004M	36.0 ~ 47.0	165.1	196.9	250.9	363.6	#4	1/4"	PR120317

TAPER SHANK HOLDER STANDARD LENGTH - Spiral Flute

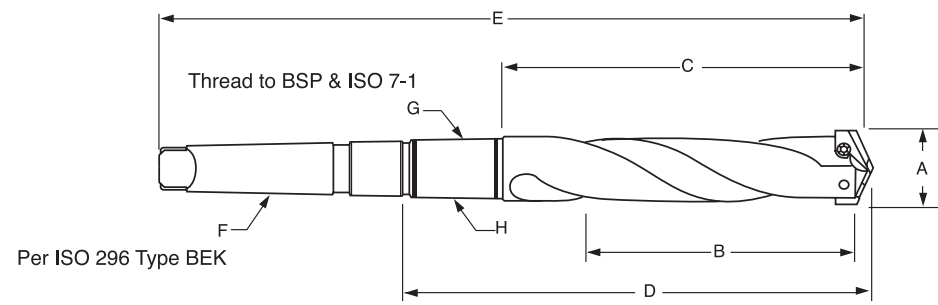

Series	EDP No.	A	B	C	D	E	F	G	H
		Drill Insert Range	Max. Drill Depth	Flute Length	Ref. Length	Overall Length	MT	Pipe Tap	RCA
Y	8Y4250002M	9.5 ~ 11.0	60.3	80.2	116.7	188.9	#2	1/16"	PR120190
Z	8Z4250002M	11.5 ~ 12.5	60.3	80.2	116.7	188.9	#2	1/16"	PR120190
0	804250002M	13.0 ~ 17.5	63.5	84.1	121.0	192.9	#2	1/16"	PR120190
0.5	814250002M	15.5 ~ 17.5	63.5	84.1	121.0	192.9	#2	1/16"	PR120190
1	824250003M	18.0 ~ 24.0	171.5	200.0	244.1	334.2	#3	1/8"	PR120254
1.5	834250003M	22.0 ~ 24.0	171.5	200.0	244.1	334.2	#3	1/8"	PR120254
2	844250004M	25.0 ~ 35.0	187.3	215.9	262.0	375.4	#4	1/8"	PR120254
2.5	854250004M	30.0 ~ 35.0	187.3	215.9	269.2	382.6	#4	1/4"	PR120317
3	864250004M	36.0 ~ 47.0	209.5	241.3	295.3	408.0	#4	1/4"	PR120317
4	874250005M	48.0 ~ 65.0	231.8	266.7	320.7	465.1	#5	1/4"	PR120444
5	884250005M	64.0 ~ 88.0	273.1	317.5	388.9	531.8	#5	1/2"	PR120571
7	894250005M	90.0 ~ 114.0	273.1	327.0	398.5	541.3	#5	1/2"	PR120571

TAPER SHANK HOLDER-EXTENDED LENGTH - Spiral Flute

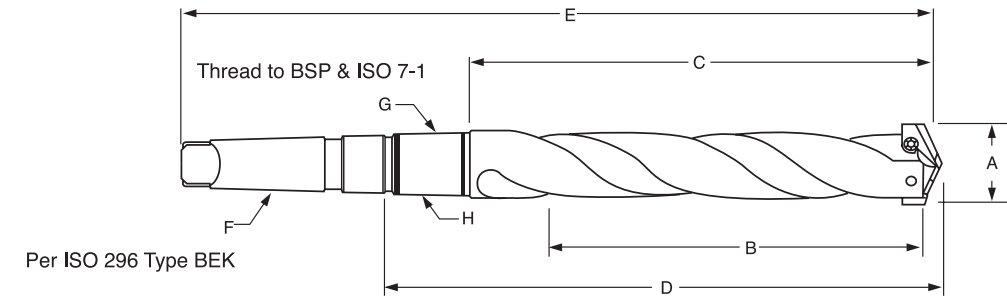

Series	EDP No.	A	B	C	D	E	F	G	H
		Drill Insert Range	Max. Drill Depth	Flute Length	Ref. Length	Overall Length	MT	Pipe Tap	RCA
Y	8Y5250002M	9.5 ~ 11.0	111.1	130.9	167.4	239.7	#2	1/16"	PR120190
Z	8Z5250002M	11.5 ~ 12.5	111.1	130.9	167.4	239.7	#2	1/16"	PR120190
0	805250002M	13.0 ~ 17.5	114.3	135.0	171.8	243.7	#2	1/16"	PR120190
0.5	815250002M	15.5 ~ 17.5	114.3	135.0	171.8	243.7	#2	1/16"	PR120190
1	825250003M	18.0 ~ 24.0	273.1	301.6	345.7	435.8	#3	1/8"	PR120254
1.5	835250003M	22.0 ~ 24.0	273.1	301.6	345.7	435.8	#3	1/8"	PR120254
2	845250004M	25.0 ~ 35.0	289.0	317.5	363.6	477.0	#4	1/8"	PR120254
2.5	855250004M	30.0 ~ 35.0	289.0	317.5	370.8	484.2	#4	1/4"	PR120317

TAPER SHANK HOLDER-EXTENDED LENGTH - Straight Flute

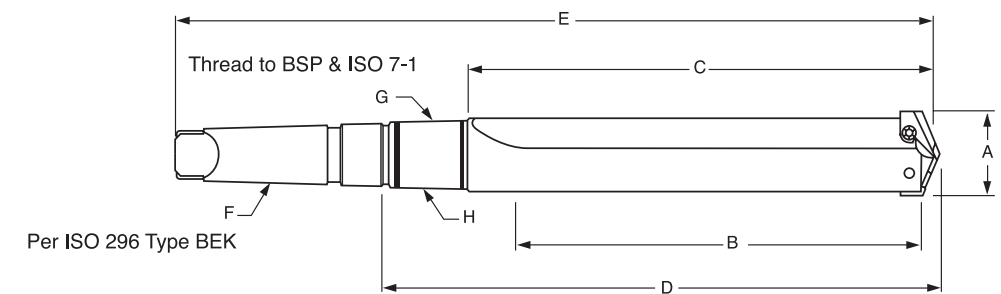

Series	EDP No.	A	B	C	D	E	F	G	H
		Drill Insert Range	Max. Drill Depth	Flute Length	Ref. Length	Overall Length	MT	Pipe Tap	RCA
3	865150004M	36.0 ~ 47.0	349.3	381.0	435.0	547.7	#4	1/4"	PR120317
4	875150005M	48.0 ~ 65.0	422.3	457.2	511.2	655.6	#5	1/4"	PR120444
5	885150005M	64.0 ~ 88.0	463.6	508.0	579.4	722.3	#5	1/2"	PR120571
7	895150005M	90.0 ~ 114.0	555.6	609.6	681.1	823.9	#5	1/2"	PR120571

FLANGED STRAIGHT SHANK HOLDERS-STUB LENGTH - Straight Flute

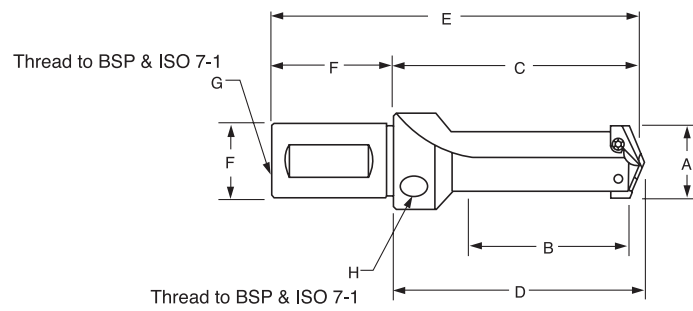

Series	EDP No.	A Drill Insert Range	B Max. Drill Depth	C Flute Length	D Ref. Length	E Overall Length	F Shank		G Pipe Tap	
							Dia.	Length	Rear	Side
Y	8Y115016FM	9.5 ~ 11.0	19.1	47.6	50.0	89.5	16.0	41.9	1/16"	1/8"
Z	8Z115016FM	11.5 ~ 12.5	19.1	47.6	50.0	89.5	16.0	41.9	1/16"	1/8"
0	80115020FM	13.0 ~ 17.5	22.2	47.6	50.4	89.5	20.0	41.9	1/8"	1/8"
0.5	81115020FM	15.5 ~ 17.5	22.2	47.6	50.4	89.5	20.0	41.9	1/8"	1/8"
1	82115025FM	18.0 ~ 24.0	47.6	75.8	79.4	128.9	25.0	53.1	1/8"	1/8"
1.5	83115025FM	22.0 ~ 24.0	57.2	88.5	92.1	141.6	25.0	53.1	1/8"	1/8"
2	84115032FM	25.0 ~ 35.0	57.2	88.5	92.1	146.4	32.0	57.9	1/4"	1/8"

FLANGED STRAIGHT SHANK HOLDER INTERMEDIATE LENGTH - Spiral Flute

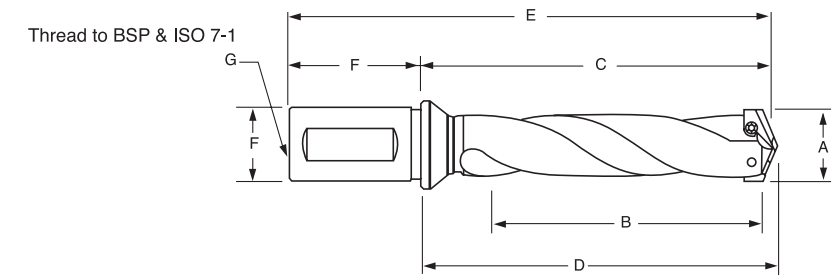

Series	EDP No.	A Drill Insert Range	B Max. Drill Depth	C Flute Length	D Ref. Length	E Overall Length	F Shank		G Pipe Tap
							Dia.	Length	
1	82325025FM	18.0 ~ 24.0	117.5	154.8	158.4	207.9	25.0	53.1	1/8"
1.5	83325025FM	22.0 ~ 24.0	117.5	154.8	158.4	207.9	25.0	53.1	1/8"
2	84325032FM	25.0 ~ 35.0	136.5	179.4	183.0	237.3	32.0	57.9	1/4"
2.5	85325032FM	30.0 ~ 35.0	136.5	179.4	183.0	237.3	32.0	57.9	1/4"
3	86325040FM	36.0 ~ 47.0	165.1	217.5	222.3	287.6	40.0	70.1	1/4"

FLANGED STRAIGHT SHANK HOLDERS-SHORT LENGTH - Straight Flute

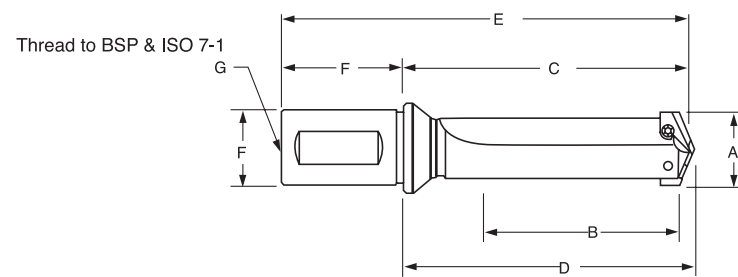

Series	EDP No.	A Drill Insert Range	B Max. Drill Depth	C Flute Length	D Ref. Length	E Overall Length	F Shank		G Pipe Tap
							Dia.	Length	
Y	8Y215020FM	9.5 ~ 11.0	31.8	61.1	63.5	103.0	20.0	41.9	1/8"
Z	8Z215020FM	11.5 ~ 12.5	31.8	61.1	63.5	103.0	20.0	41.9	1/8"
0	80215020FM	13.0 ~ 17.5	34.9	63.5	66.3	105.4	20.0	41.9	1/8"
0.5	81215020FM	15.5 ~ 17.5	34.9	63.5	66.3	105.4	20.0	41.9	1/8"
1	82215025FM	18.0 ~ 24.0	66.7	107.2	110.7	160.2	25.0	53.1	1/8"
1.5	83215025FM	22.0 ~ 24.0	66.7	107.2	110.7	160.2	25.0	53.1	1/8"
2	84215032FM	25.0 ~ 35.0	85.7	128.6	132.2	186.5	32.0	57.9	1/4"
2.5	85215032FM	30.0 ~ 35.0	85.7	128.6	132.2	186.5	32.0	57.9	1/4"
3	86215040FM	36.0 ~ 47.0	120.7	173.0	177.8	243.1	40.0	70.1	1/4"
4	87215040FM	48.0 ~ 65.0	130.2	179.4	184.2	249.5	40.0	70.1	1/4"

FLANGED STRAIGHT SHANK HOLDER-STANDARD LENGTH - Spiral Flute

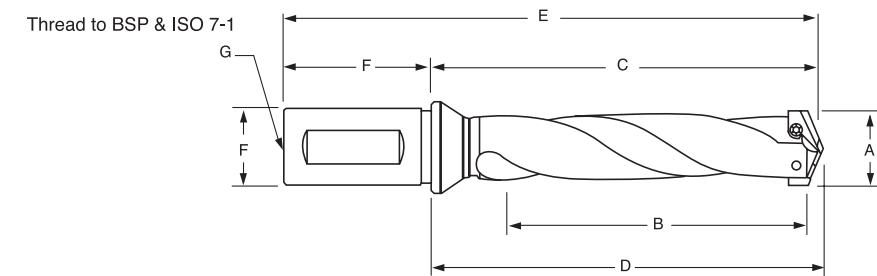

Series	EDP No.	A Drill Insert Range	B Max. Drill Depth	C Flute Length	D Ref. Length	E Overall Length	F Shank		G Pipe Tap
							Dia.	Length	
Y	8Y325020FM	9.5 ~ 11.0	60.3	89.7	92.1	131.6	20.0	41.9	1/8"
Z	8Z425020FM	11.5 ~ 12.5	60.3	89.7	92.1	131.6	20.0	41.9	1/8"
0	80425020FM	13.0 ~ 17.5	63.5	92.1	94.9	134.0	20.0	41.9	1/8"
0.5	81425020FM	15.5 ~ 17.5	63.5	92.1	94.9	134.0	20.0	41.9	1/8"
1	82425025FM	18.0 ~ 24.0	168.3	205.6	209.2	258.7	25.0	53.1	1/8"
1.5	83425025FM	22.0 ~ 24.0	168.3	205.6	209.2	258.7	25.0	53.1	1/8"
2	84425032FM	25.0 ~ 35.0	187.3	230.2	233.8	288.1	32.0	57.9	1/4"
2.5	85425032FM	30.0 ~ 35.0	187.3	230.2	233.8	288.1	32.0	57.9	1/4"
3	86425040FM	36.0 ~ 47.0	209.6	261.9	266.7	332.0	40.0	70.1	1/4"
4	87425040FM	48.0 ~ 65.0	231.8	281.0	285.8	351.1	40.0	70.1	1/4"

FLANGED STRAIGHT SHANK HOLDER-EXTENDED LENGTH - Spiral Flute

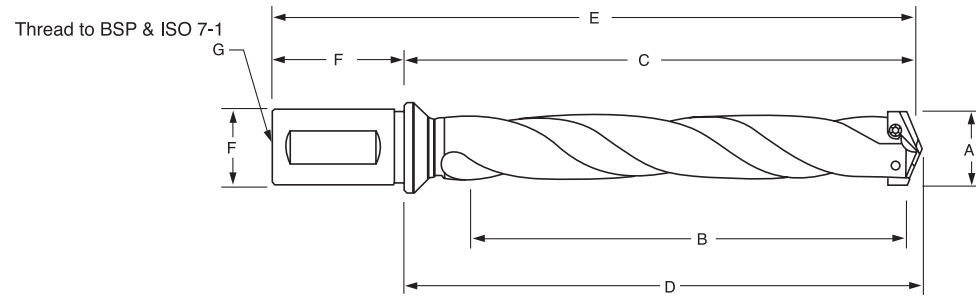

Series	EDP No.	A	B	C	D	E	F		G
		Drill Insert Range	Max. Drill Depth	Flute Length	Ref. Length	Overall Length	Dia.	Length	
Y	8Y425020FM	9.5 ~ 11.0	111.1	140.5	142.9	182.4	20.0	41.9	1/8"
Z	8Z525020FM	11.5 ~ 12.5	111.1	140.5	142.9	182.4	20.0	41.9	1/8"
0	80525020FM	13.0 ~ 17.5	114.3	142.9	145.7	184.8	20.0	41.9	1/8"
0.5	81525020FM	15.5 ~ 17.5	114.3	142.9	145.7	184.8	20.0	41.9	1/8"
1	82525025FM	18.0 ~ 24.0	269.9	307.2	310.8	360.3	25.0	53.1	1/8"
1.5	83525025FM	22.0 ~ 24.0	269.9	307.2	310.8	360.3	25.0	53.1	1/8"
2	84525032FM	25.0 ~ 35.0	288.9	331.8	335.4	389.7	32.0	57.9	1/4"
2.5	85525032FM	30.0 ~ 35.0	288.9	331.8	335.4	389.7	32.0	57.9	1/4"

FLANGED STRAIGHT SHANK HOLDER-EXTENDED LENGTH - Straight Flute

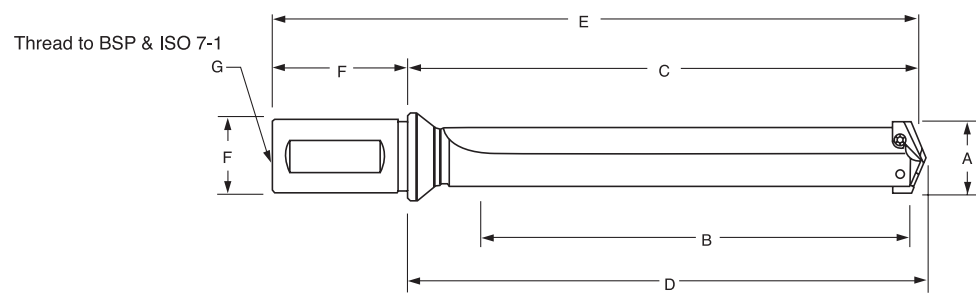

Series	EDP No.	A	B	C	D	E	F		G
		Drill Insert Range	Max. Drill Depth	Flute Length	Ref. Length	Overall Length	Dia.	Length	
3	86515040FM	36.0 ~ 47.0	349.3	401.6	406.4	471.7	40.0	70.1	1/4"
4	87515040FM	48.0 ~ 65.0	422.3	471.5	476.3	541.6	40.0	70.1	1/4"

COOLANT RINGS & TORX SCREWS / DRIVERS

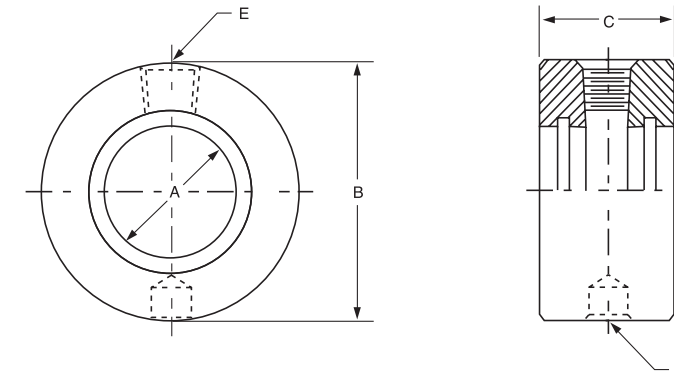

Metric

Item No.	A	B	C	D	E	RCA Repair Kit Item No.	RCA O-Ring Replacements Item No.
	I.D.	O.D.	Length	Thread for Driving Rod	Pipe Tap		
PR120190	19.05	44.45	22.23	M8 X 1.25	◆1/8"	PR220190	PR320190
PR120254	25.40	53.97	28.57	M8 X 1.25	◆1/8"	PR220254	PR320254
PR120317	31.75	63.50	34.92	M10 X 1.5	◆1/4"	PR220317	PR320317
PR120444	44.45	76.20	34.92	M10 X 1.5	◆1/4"	PR220444	PR320444
PR120571	57.15	95.27	44.45	M12 X 1.75	◆1/2"	PR220571	PR320571

◆ Thread to BSP & ISO 7-1

Torx Screws

Holder Series	Item No.	TORX Hand Driver	Drill Range Used With
Y	J07Y0010	J05Y0070	9.5 mm ~ 11.0 mm
Z	J07Z0110	J05Z0070	11.5 mm ~ 12.5 mm
0	J0800210	J0500080	13.0 mm ~ 17.5 mm
0.5	J0805310	J0505080	15.5 mm ~ 17.5 mm
1	J0910410	J0510090	18.0 mm ~ 24.0 mm
1.5	J0915510	J0515090	22.0 mm ~ 24.0 mm
2	J1520610	J0520150	25.0 mm ~ 35.0 mm
2.5	J1525710	J0525150	30.0 mm ~ 35.0 mm
3,4	J2030810	J0530200	36.0 mm ~ 65.0 mm
5 ~ 8	J2550910	J0550250	64.0 mm ~ 114.0 mm

** Note : Replacement screws sold in packages(10 screws per package)